



**20MM OUTDOOR
PORCELAIN TILES**
COLLECTION - 2023-'24

WIN-TEL
DIGITAL VITRIFIED TILES

**A CONFLUENCE OF
NATURE & TECHNOLOGY**



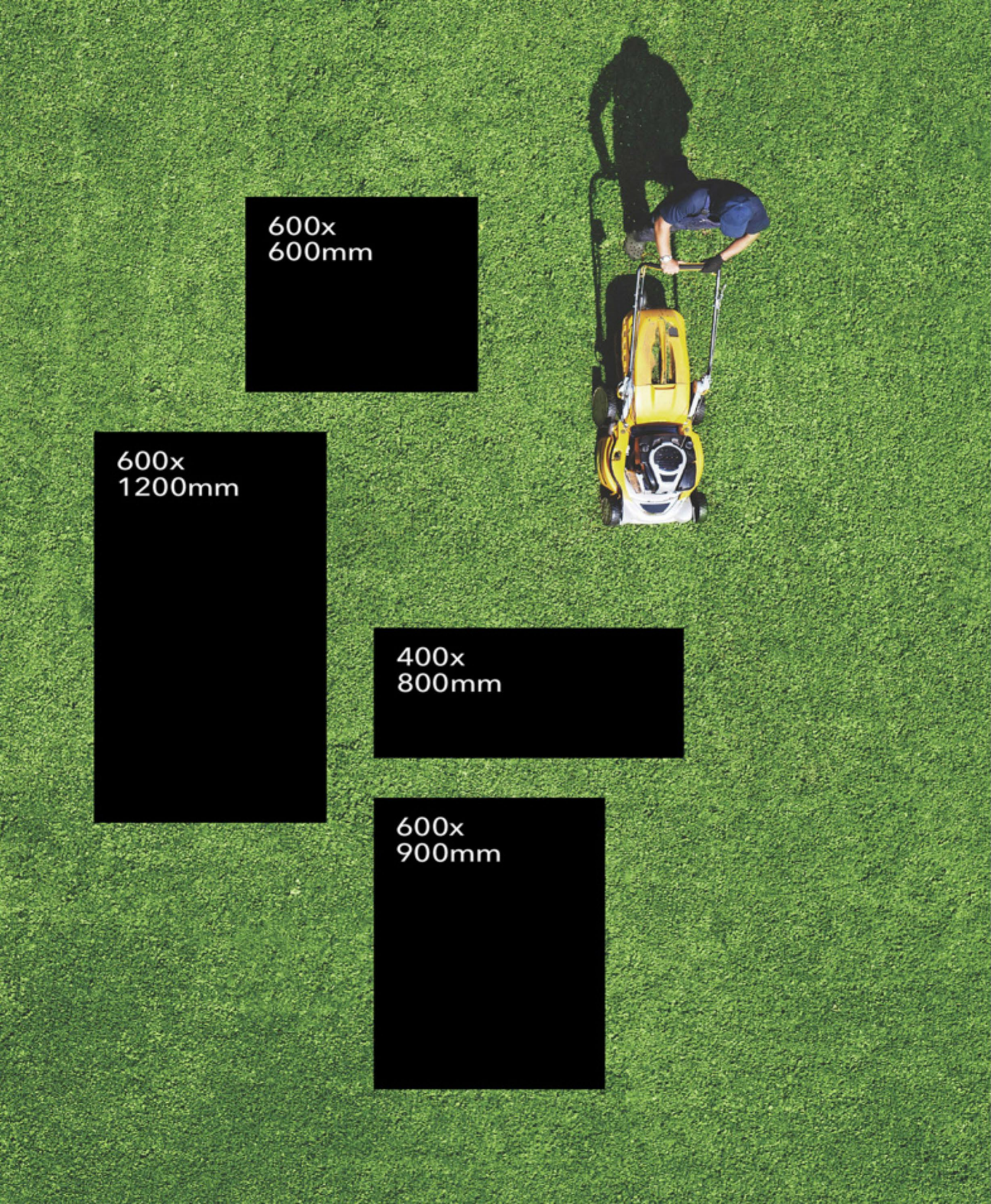

600x
600mm

600x
1200mm

400x
800mm

600x
900mm

20MM OUTDOOR PORCELAIN TILES

DISCOVER THE COLLECTION OF RESILIENT SURFACES CRAFTED WITH THE CONVERGENCE OF NATURE AND TECHNOLOGY FOR DEMANDING OUTDOORS AND AREAS THAT ARE AN EXTENSION OF YOUR HOMES AND SPACES.

The outdoors of your homes and spaces are the first impression that you make on your guests and they are also the places that endure the most. Keeping in mind the aesthetics, functionality, and resilience your outdoor spaces require, Our is here with an exclusive collection of outdoor tiles which is packed with superior aesthetics, endurance, and functionality that will not let you compromise on the outdoor tiling of

your spaces and transform those areas in practical and presentable spaces. The exclusive collection offers outdoor colorbody tiles in robust 20mm thickness and four versatile sizes 600x1200mm, 600x900mm, 600x600mm, and 400x800mm that cater to every tiling need. Packed with a plethora of features the collection blends strength, style, and resilience in your spaces.

TILE LAYING POSSIBILITIES

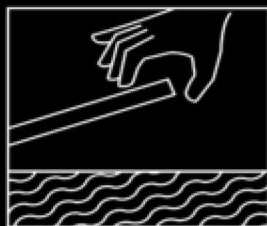

LAYING ON SCREED WITH ADHESIVES



Laying on screed with adhesives
Lay the 20mm outdoor tiles on a bed of screed with adhesives for heavy traffic areas like parking, courtyards, and others like swimming pool borders, outdoor flooring, sit-out areas, and more.

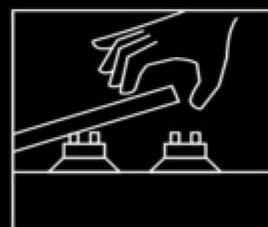

LAYING ON A RAISED FLOOR

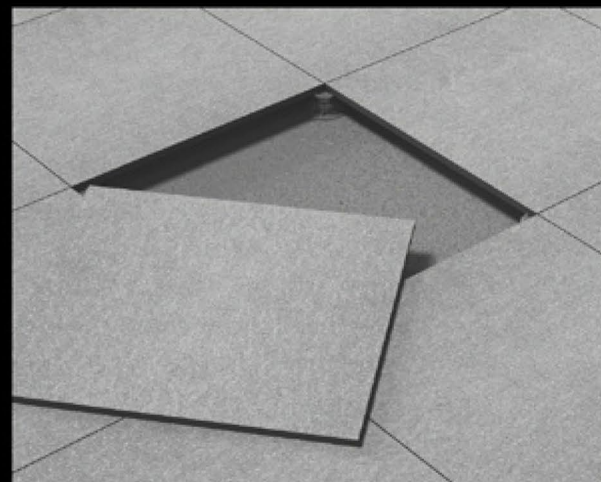

Tile uneven areas, terrains, and more and transform them enduring by laying 20mm outdoor tiles on raised floor pedestals, frames, and more. Create room for a heating system, insulation, additional raised area, and more with the extensive laying possibilities of this collection.

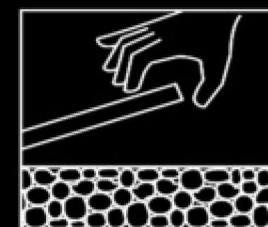

LAYING ON GRAVEL

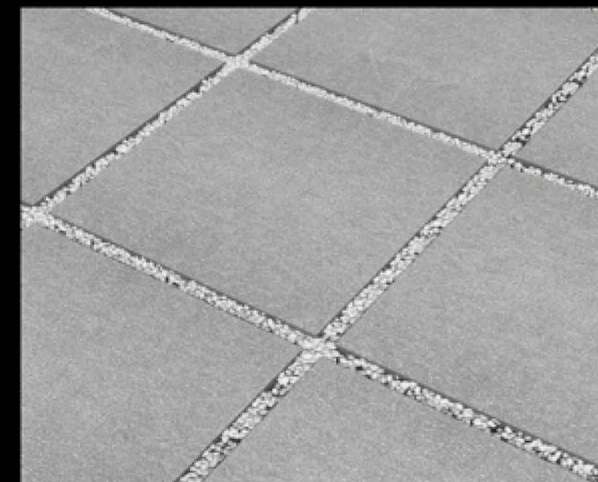

The robust and resilient collection is ideal for laying directly on gravel in your outdoors with or without adhesive. Create a stepping stone path, patio, and more by just laying the thick tiles on the gravel in your outdoors.



DRY LAYING ON THE GRASS



Shape elegant pathways, outdoor leisure areas, and more by dry laying the 20mm outdoor tiles on the grass in your gardens and other areas surrounding the building. The laying possibility opens door to fuss-free outdoor tiling.



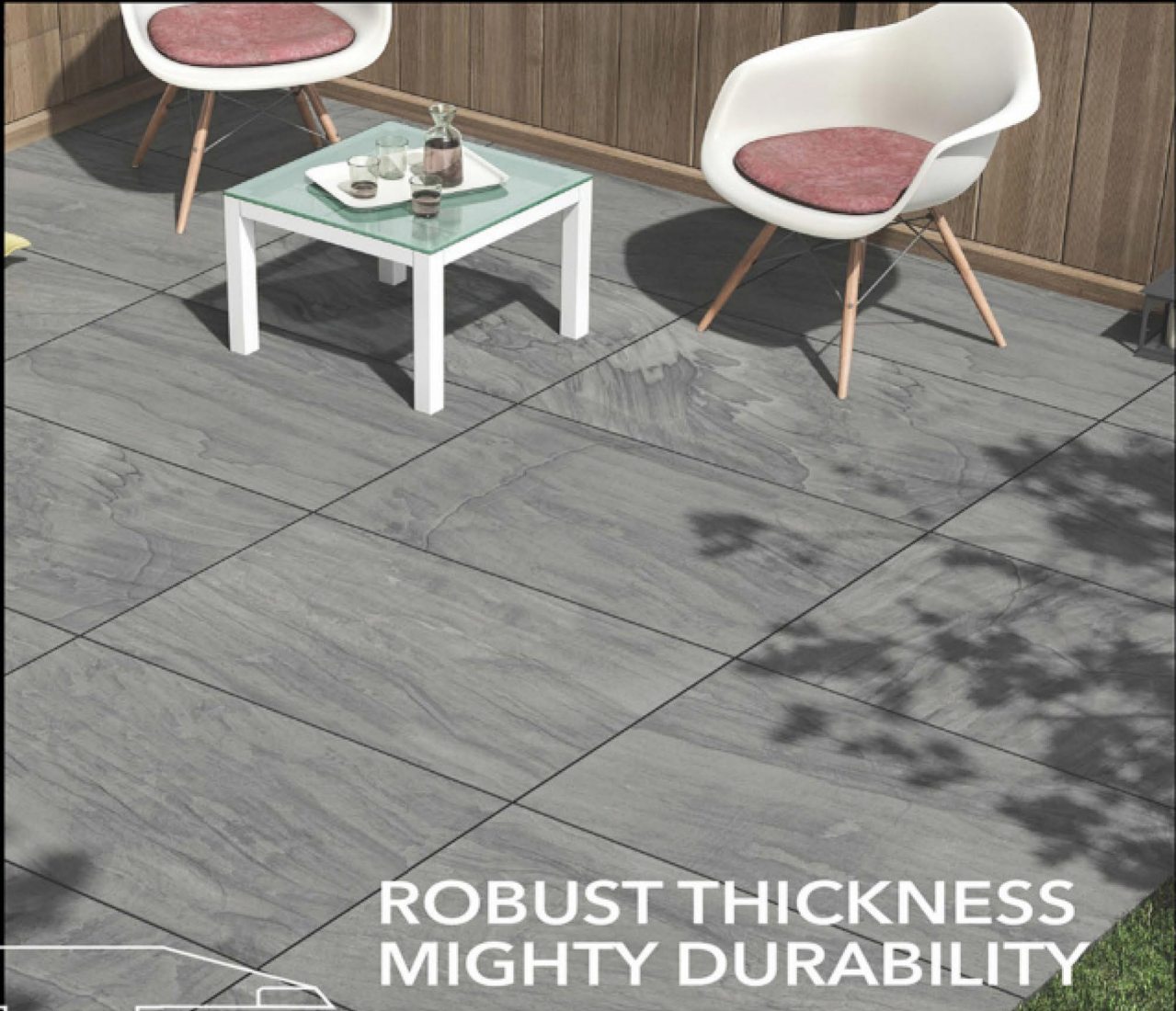

BENIFITS OF 20MM OUTDOOR TILES

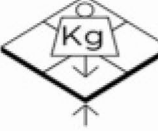

**ROBUST THICKNESS
MIGHTY DURABILITY**

20MM

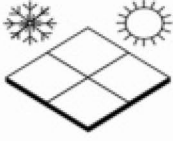
The substantial thickness of 20mm of the collection lends the surfaces exceptional durability and resilience. The thickness offers surfaces durability to endure heavy traffic, weight, and rugged use and makes the surfaces practically ideal for all kinds of usages. The thickness paired with R11 anti-skid surfaces makes the surfaces of the collection extremely safe for use outdoors.

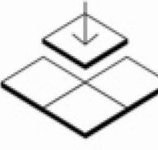
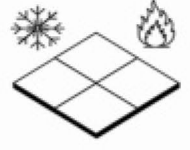
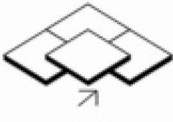
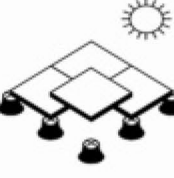
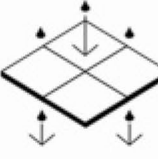
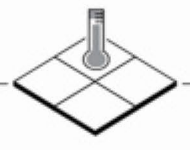
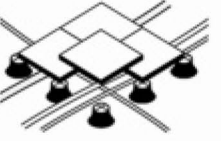
 <p>Stress-resistant</p>	 <p>High tensile strength</p>	 <p>Antislip (R11)</p>	 <p>Weather resistant</p>
 <p>Easy to clean due to the lack of adhesives and filler</p>	 <p>Easy to install even without adhesives or filler</p>	 <p>Frost and fire-resistant</p>	 <p>Removable and reusable</p>
 <p>Ideal for paving outdoor installations, including raised paving.</p>	 <p>Good drainage, facilitates the flow of water and rainfall, eliminating harmful stagnation</p>	 <p>Highly resistant to changes in temperature</p>	 <p>Easily inspected and functional, allows installation and maintenance of cabling and pipework.</p>

The robustly crafted collection comes with a plethora of features and benefits and aids in an effortless and risk-free lifestyle with attributes like r11 anti-slip surfaces, resistance to heat, frost, fire, weather, stains, and more, and also very easy to maintain. On top of features, the surfaces are easy to install, removable, and reusable.

APPLICATIONS AND SOLUTIONS

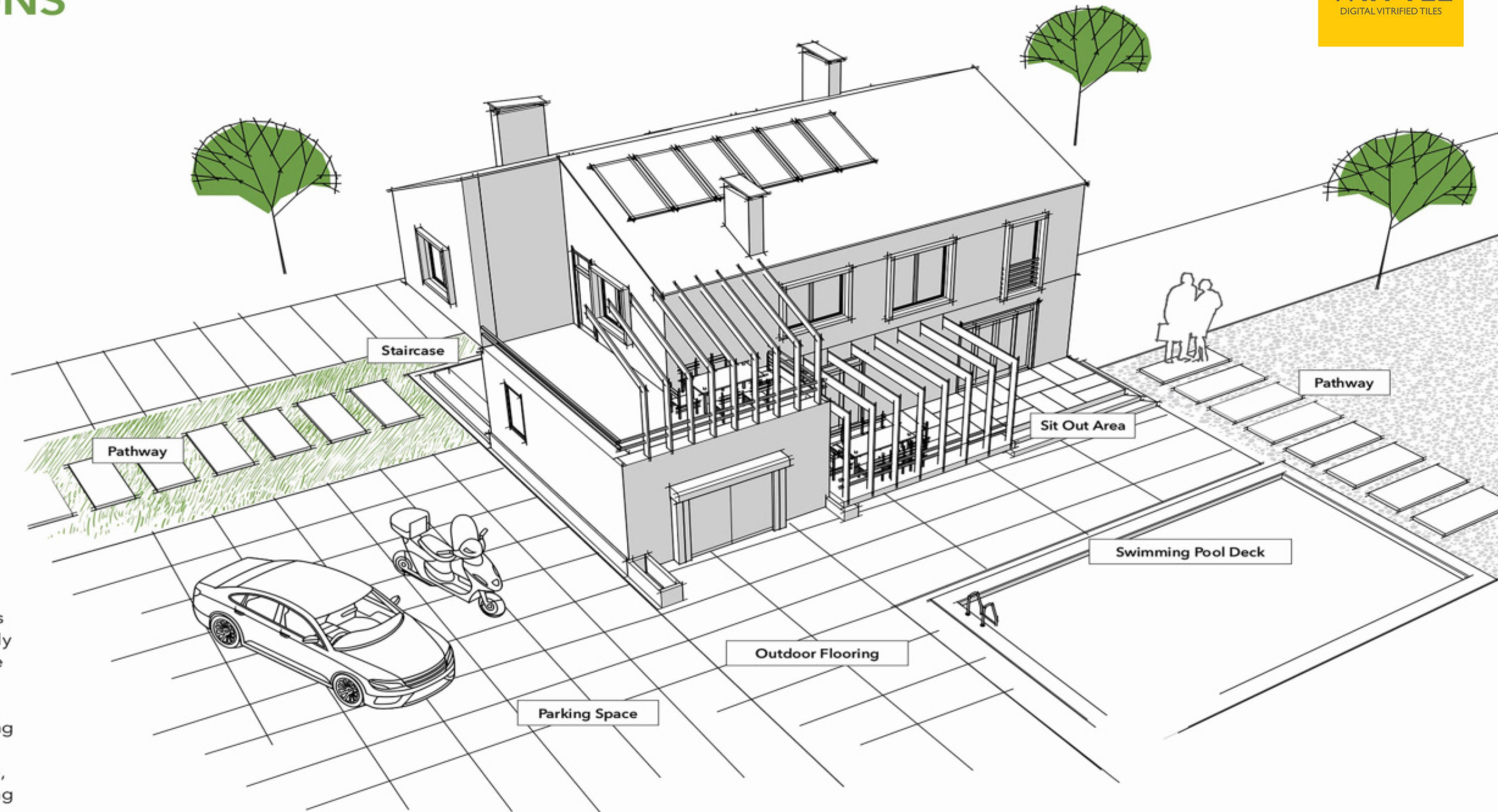

DESIGN YOUR OUTDOOR SPACES

The extensive application possibilities of the collection allow you to elegantly and practically tile your outdoors. The versatile and extremely durable collection due to its functional characteristics is ideal for tiling parking spaces, outdoor floors, staircases, pathways, benches, outdoor furniture, pavements, patios, gardens, swimming pool decks, and more.

Enjoy your outdoor worry-free with the superior blend of strength and aesthetics of the 20mm outdoor collection of Our crafted to help you appreciate your outdoors.

APPLICATION AREAS

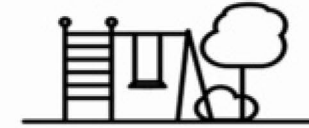

Public Parks
& Gardens



Terraces &
Balconies

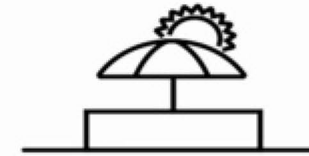

Beach
Resorts

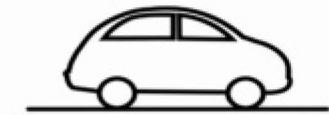

Parking
Lots

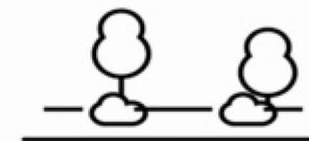

Driveways &
Pathways



Swimming
Pool Decks



Street
Furniture



High-Traffic
Industrial Areas

LAYING PATTERNS



ACHIEVE VISUALLY APPEALING OUTDOORS WITH MULTIPLE LAYING PATTERN POSSIBILITIES.

Explore extensive tile-laying pattern possibilities with the multiple sizes of the 20mm outdoor tile collection. The four different sizes of the collection allow you to mix and match tile sizes for a unique lay in your spaces. Mix two or

more sizes and spruce up your tiling game outdoors with the elegant tile-laying combination possibilities with the versatile tile sizes and robust thickness of the collection ideal for reusing and relocating tiles.

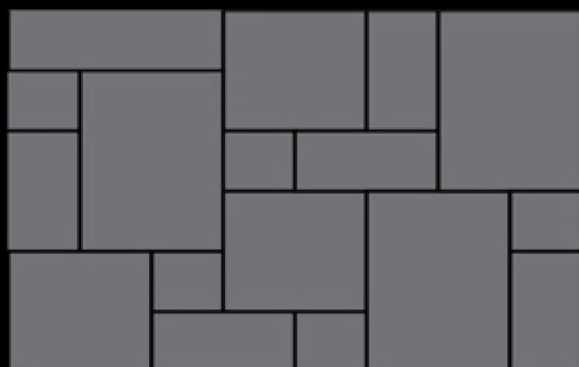

Tiles Combination
600x900mm, 600x600mm, 300x600mm, 300x300mm

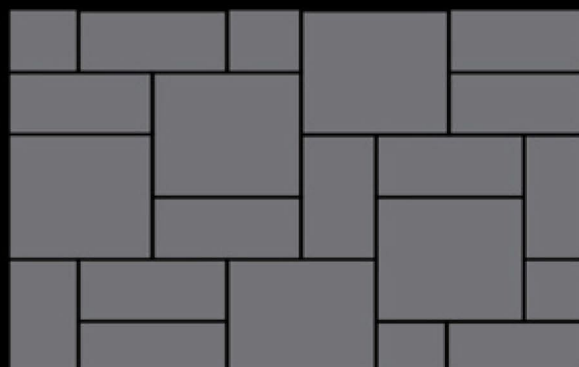

Tiles Combination
600x600mm, 300x600mm



Tiles Combination
600x900mm, 600x600mm

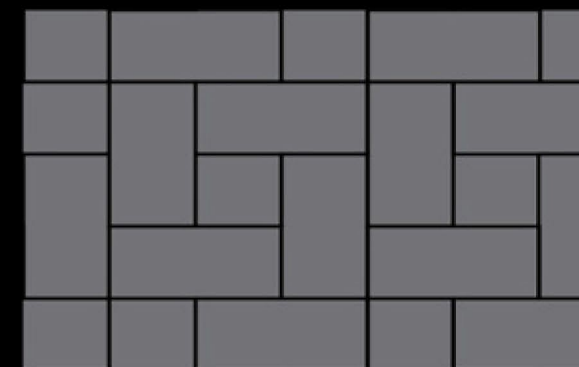

Tiles Combination
600x1200mm, 600x600mm

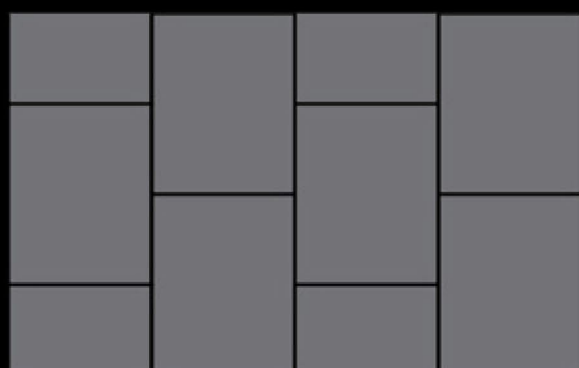

Tiles Combination
600x900mm



Tiles Combination
600x600mm, 300x300mm



Tiles Combination
600x600mm, 300x600mm

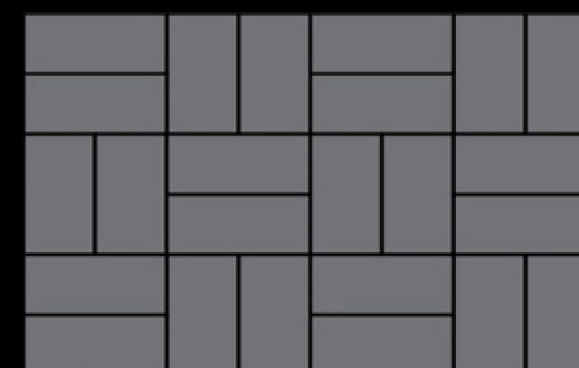

Tiles Combination
300x600mm

R11

ALFRESCO WOOD

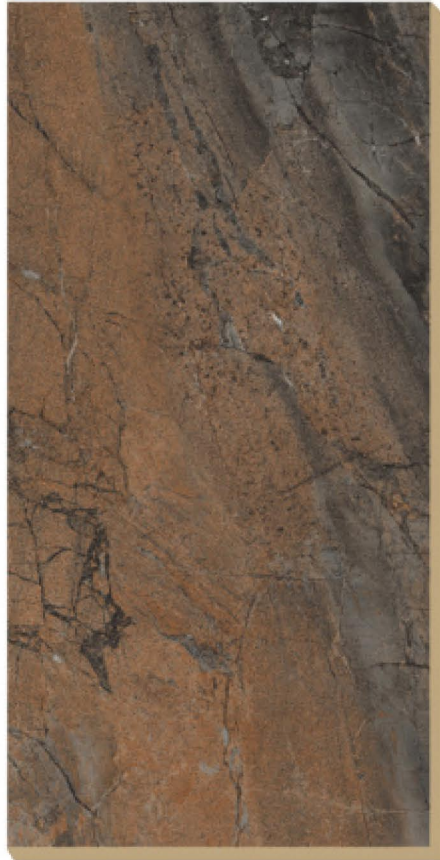

600x1200 MM



600x900 MM



600x600 MM

800x800 MM

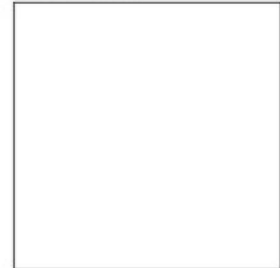

DIFFERENT SIZES

400x800 MM



COBBLES, BULLNOSE

300x600 MM



300x300 MM



100x200 MM

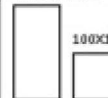

100x100 MM



800x1200 MM



200x1200 MM



300x900 MM



200x900 MM



STRIPS



**20MM OUTDOOR
PORCELAIN TILES**



ALFRESCO WOOD-600X600 MM

20
MM
THICKNESS



R11

AMALFI CREMA



600x1200 MM

600x900 MM

600x600 MM

800x800 MM

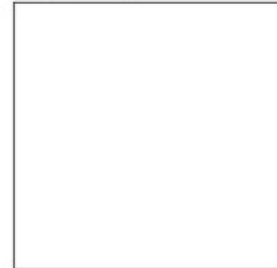

DIFFERENT SIZES

400x800 MM



COBBLES, BULLNOSE

300x600 MM



300x300 MM



100x200 MM

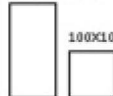

100x100 MM



800x1200 MM



200x1200 MM



800x900 MM



200x900 MM



STRIPS

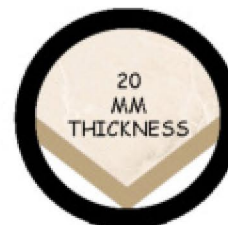

**20MM OUTDOOR
PORCELAIN TILES**



AMALFI CREMA-600X900 MM

20
MM
THICKNESS



R11

AMALFI GREY



600x1200 MM

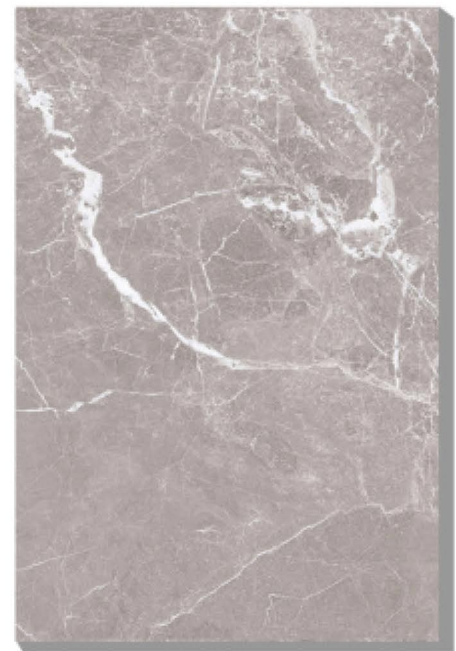

600x900 MM



600x600 MM



DIFFERENT SIZES

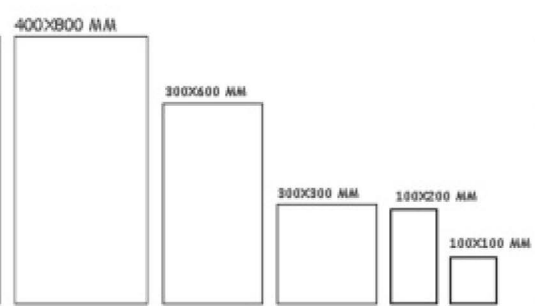

COBBLES, BULLNOSE

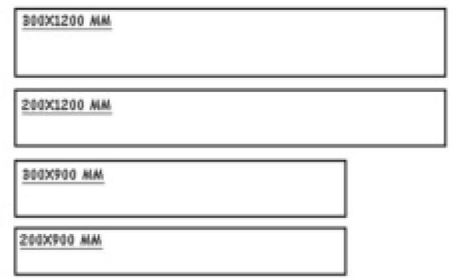

STRIPS

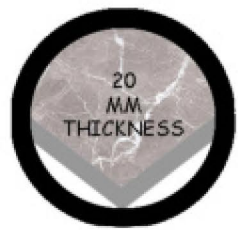

**20MM OUTDOOR
PORCELAIN TILES**



AMALFI GREY-600X1200 MM

20
MM
THICKNESS

R11

AOSTA WHITE

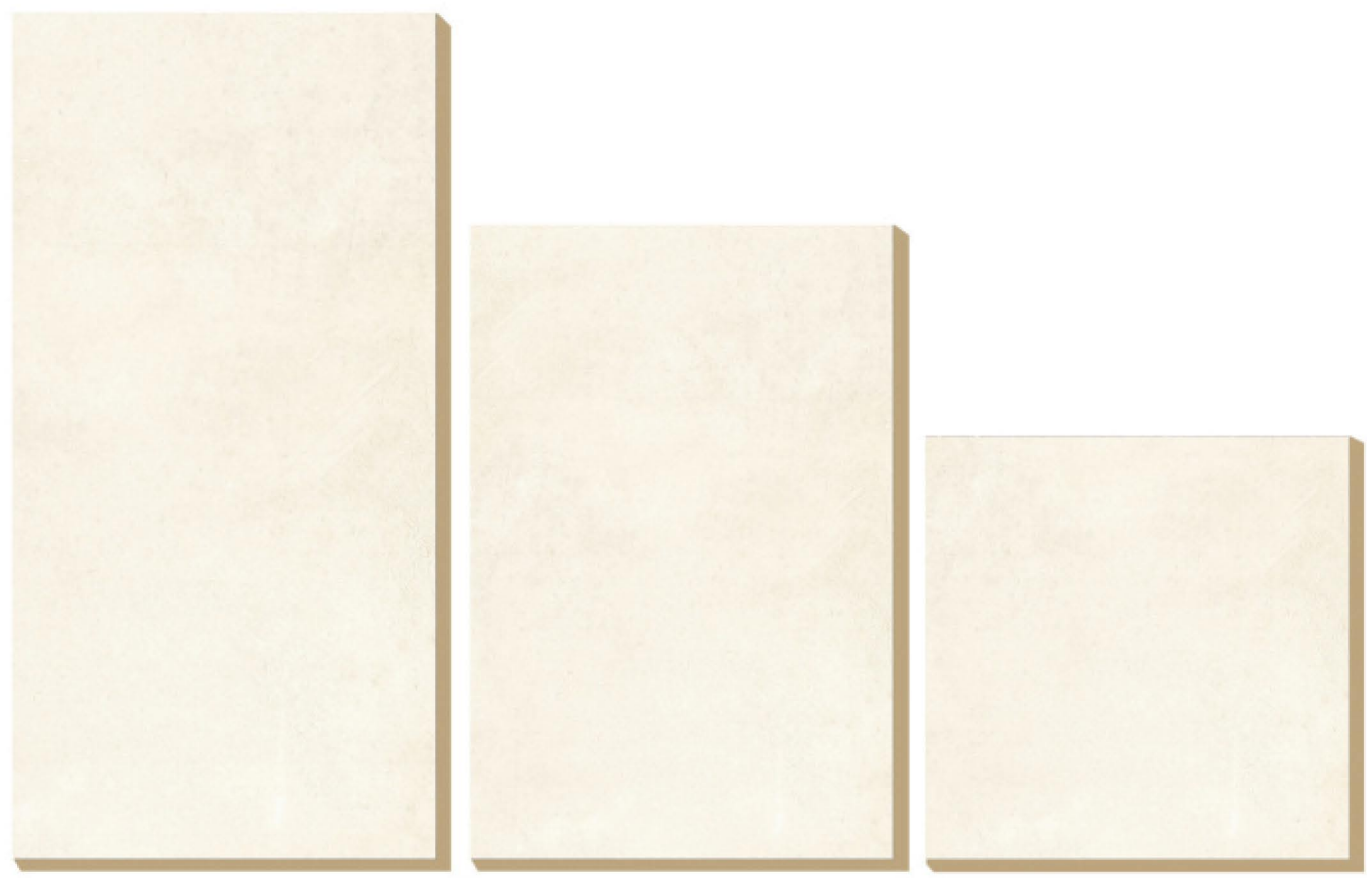

600x1200 MM 600x900 MM 600x600 MM

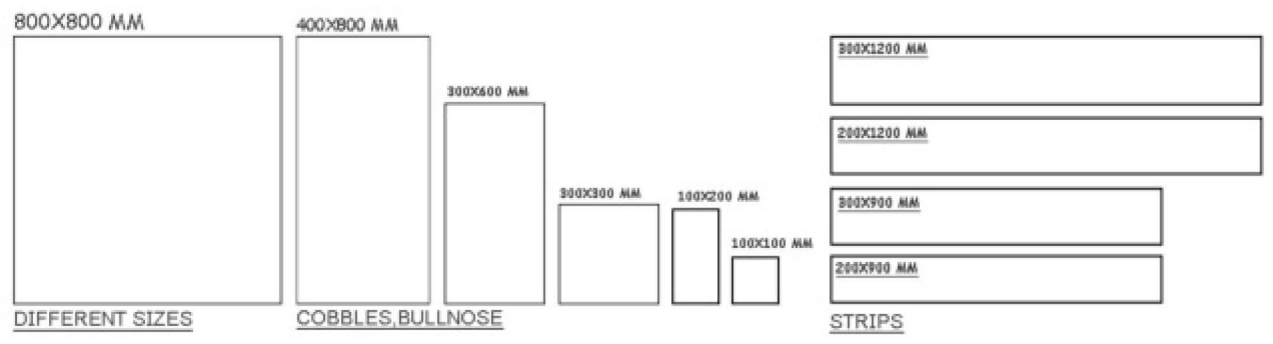

**20
MM
THICKNESS**

**20MM OUTDOOR
PORCELAIN TILES**



AOSTA WHITE-600X900 MM

20
MM
THICKNESS



R11

AUTUMN RUSTIC



600x1200 MM



600x900 MM



600x600 MM

800x800 MM

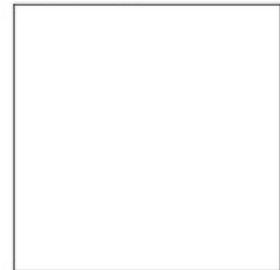

DIFFERENT SIZES

400x800 MM



COBBLES, BULLNOSE

300x600 MM



300x300 MM



100x200 MM

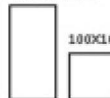

100x100 MM



800x1200 MM



200x1200 MM



800x900 MM



200x900 MM



STRIPS



**20MM OUTDOOR
PORCELAIN TILES**



AUTUMN RUSTIC 600X1200 MM

20
MM
THICKNESS



R11

BLUE STONE NATURAL



600x1200 MM

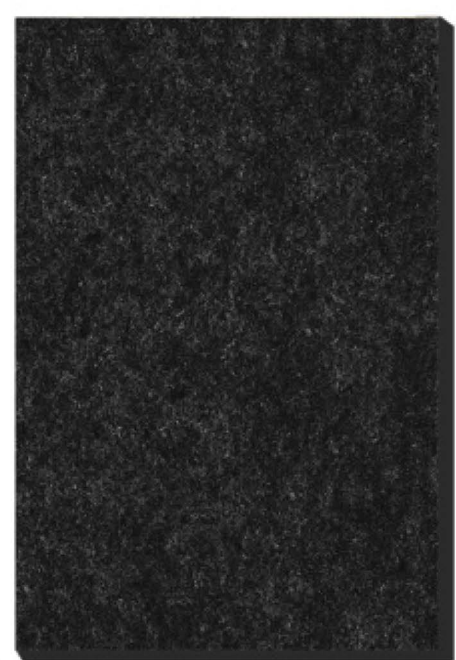

600x900 MM



600x600 MM



DIFFERENT SIZES

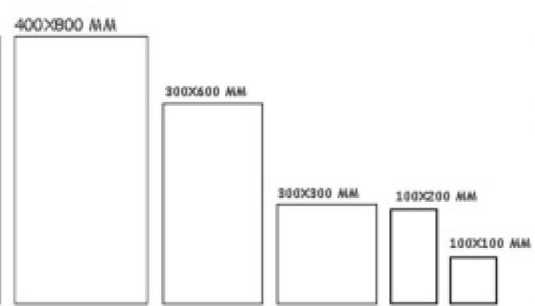

COBBLES, BULLNOSE

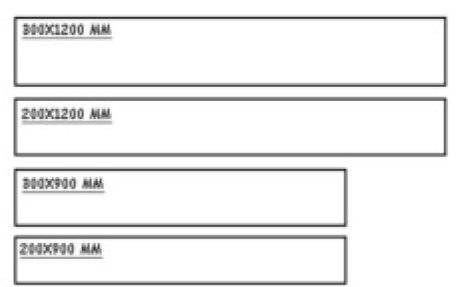

STRIPS



**20MM OUTDOOR
PORCELAIN TILES**



BLUE STONE NATURAL-600X600 MM

20
MM
THICKNESS



R11

BLUE STONE COIN



600x1200 MM



600x900 MM



600x600 MM

800x800 MM



DIFFERENT SIZES

400x800 MM



COBBLES, BULLNOSE

300x600 MM



300x300 MM



100x200 MM

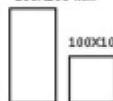

100x100 MM



800x1200 MM



200x1200 MM



800x900 MM



200x900 MM



STRIPS

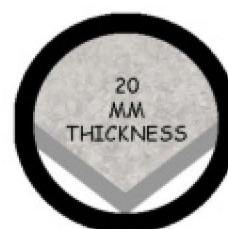

**20MM OUTDOOR
PORCELAIN TILES**



BLUE STONE COIN-600X900 MM

20
MM
THICKNESS



R11

BRAZILIAN BLACK



600x1200 MM



600x900 MM



600x600 MM



DIFFERENT SIZES

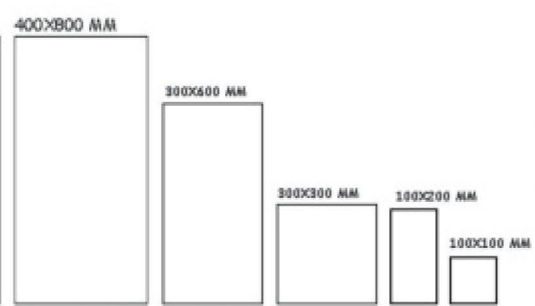

COBBLES, BULLNOSE

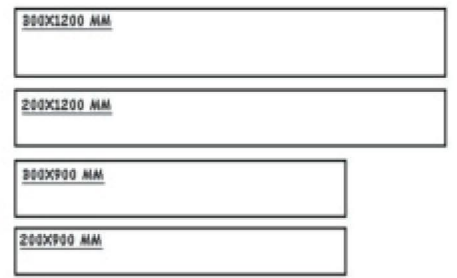

STRIPS



**20MM OUTDOOR
PORCELAIN TILES**

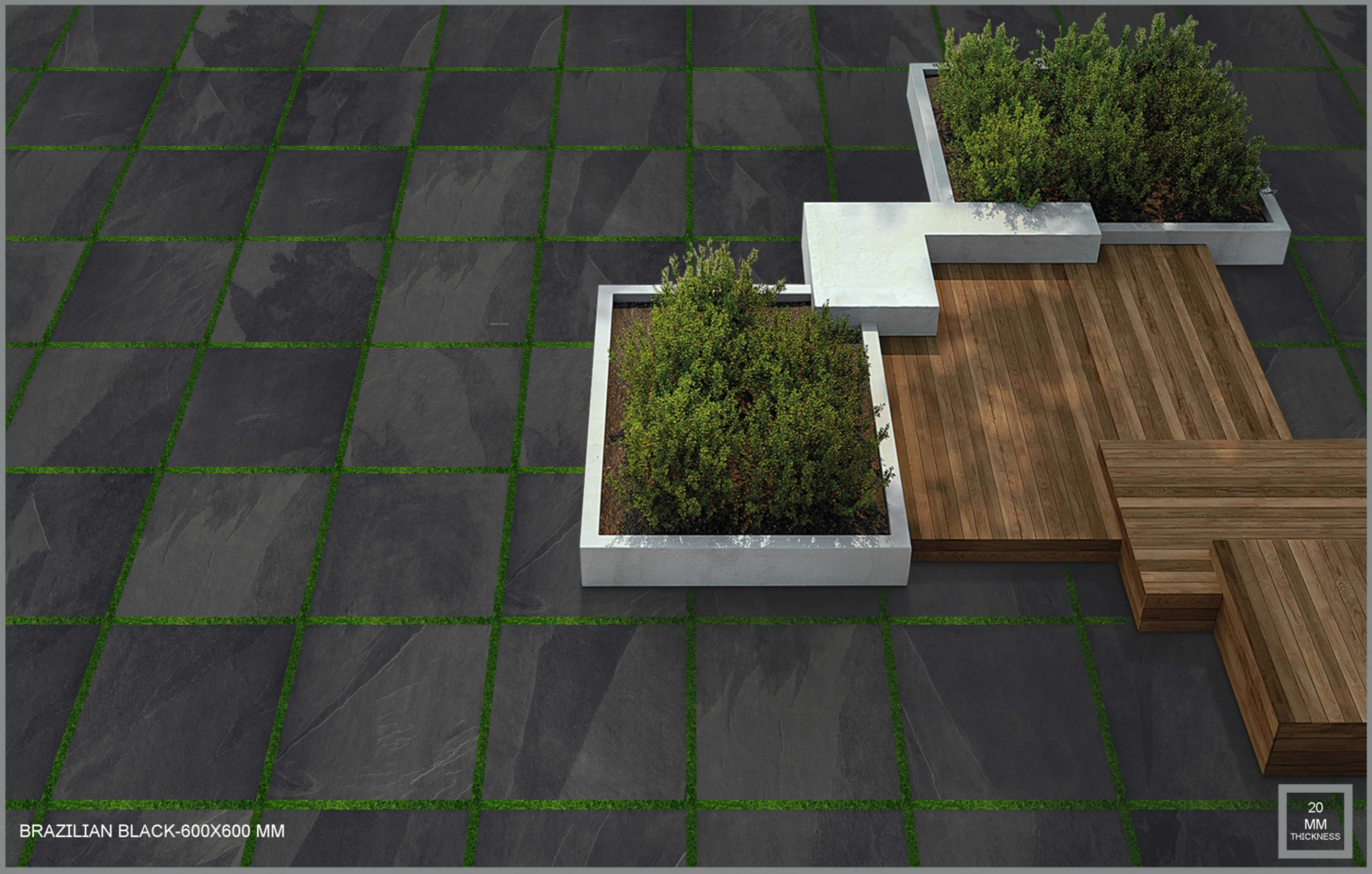

BRAZILIAN BLACK-600X600 MM

20
MM
THICKNESS



R11

BRAZILIAN GREY

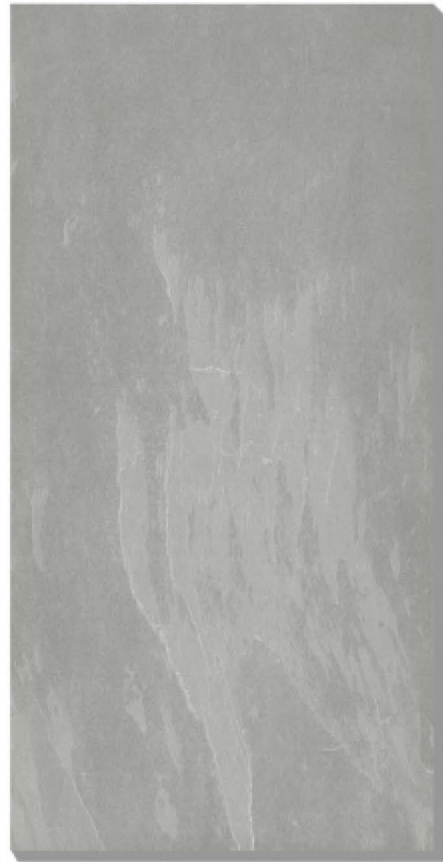

600x1200 MM



600x900 MM



600x600 MM

800x800 MM

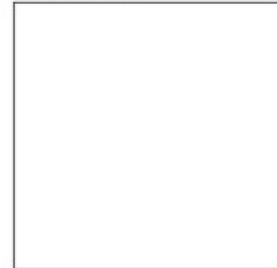

DIFFERENT SIZES

400x800 MM



COBBLES, BULLNOSE

300x600 MM



300x300 MM



100x200 MM

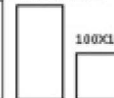

100x100 MM



800x1200 MM



200x1200 MM



300x900 MM



200x900 MM



STRIPS



**20MM OUTDOOR
PORCELAIN TILES**



BRAZILIAN GREY-600X900 MM

20
MM
THICKNESS



R11

CEMENTINO ASH

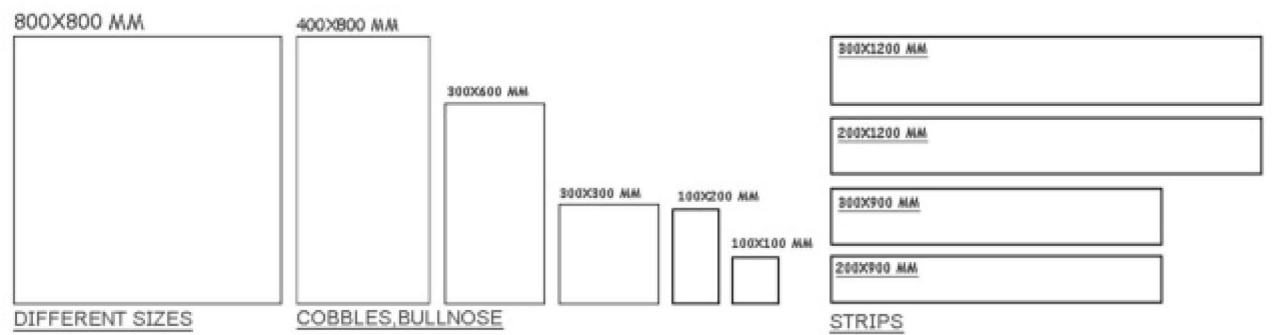
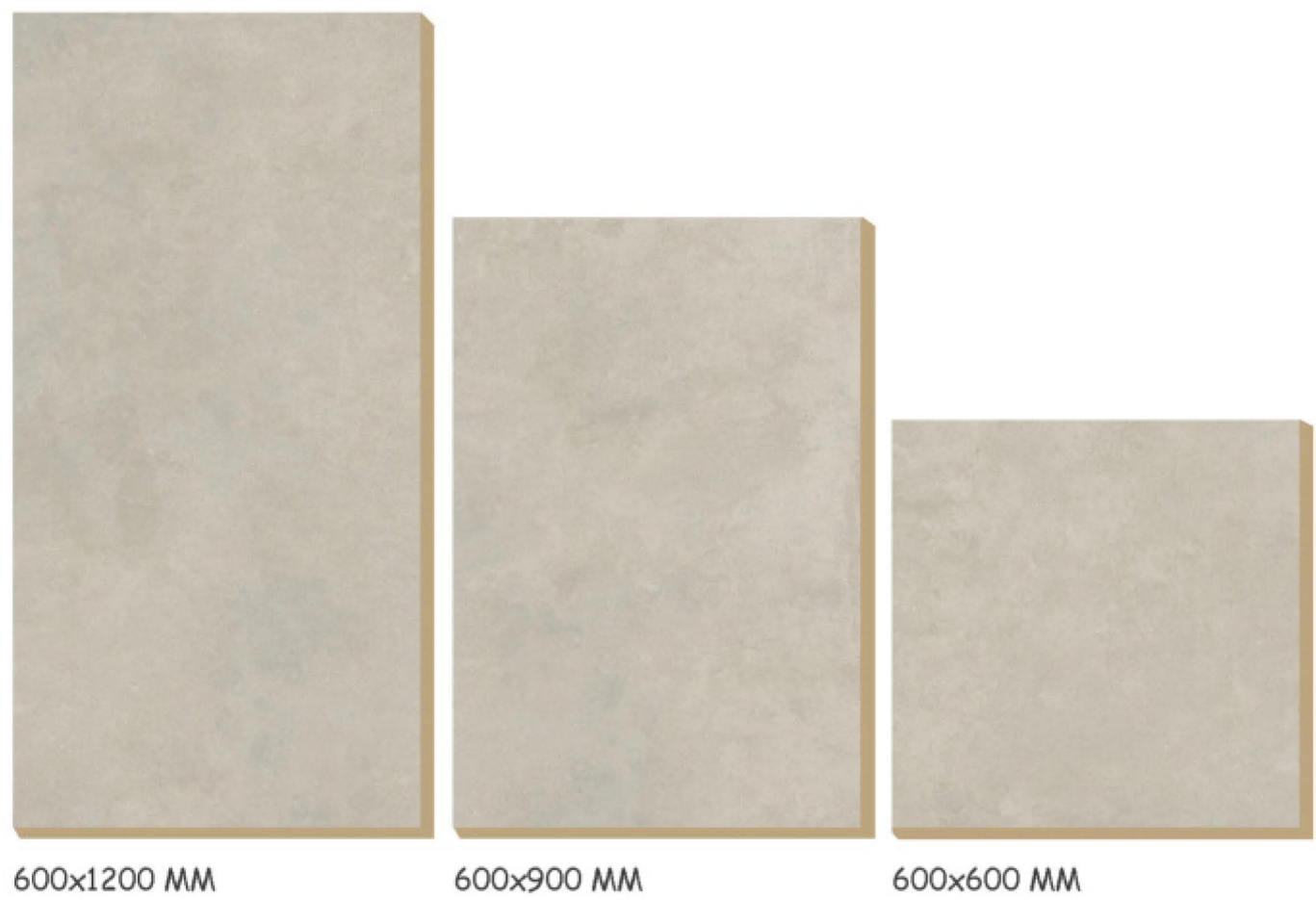

20
MM
THICKNESS

**20MM OUTDOOR
PORCELAIN TILES**



CEMENTINO ASH 600X600 MM

20
MM
THICKNESS



R11

CEMENTINO BEIGE



600x1200 MM 600x900 MM 600x600 MM

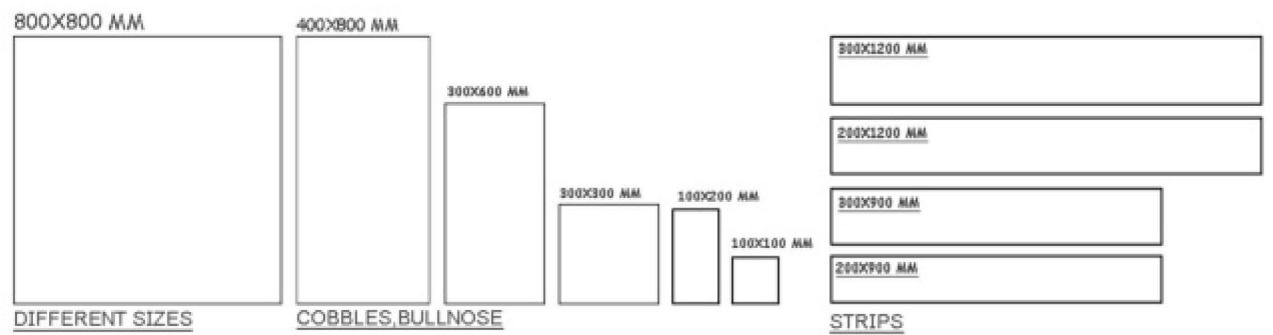

**20
MM
THICKNESS**

**20MM OUTDOOR
PORCELAIN TILES**

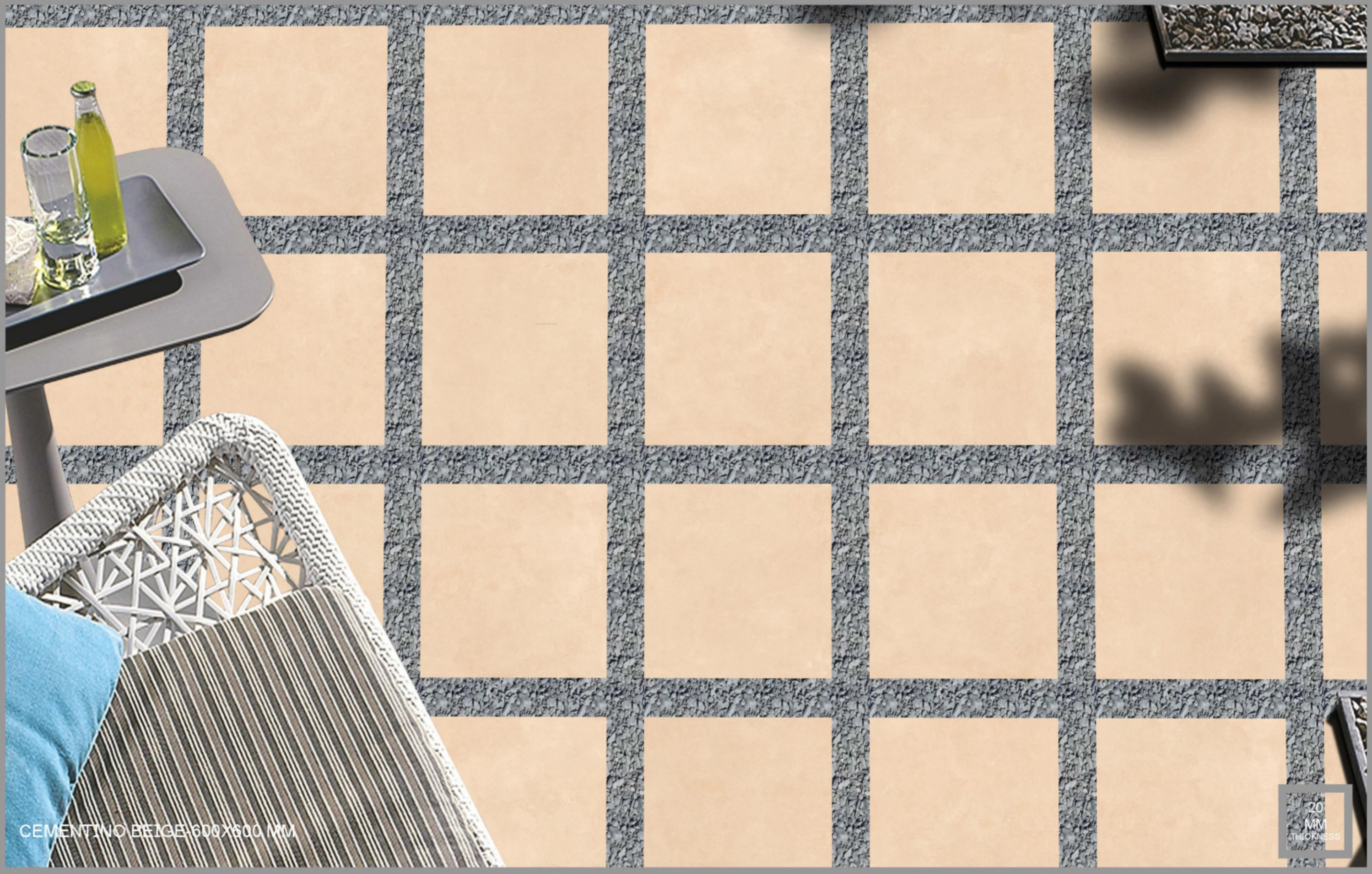

CEMENTINO BEIGE 600X600 MM

20
MM
THICKNESS



R11

CEMENTINO GREY



600x1200 MM



600x900 MM



600x600 MM

800x800 MM

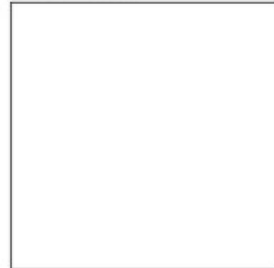

DIFFERENT SIZES

400x800 MM



COBBLES, BULLNOSE

300x600 MM



300x300 MM



100x200 MM



100x100 MM



800x1200 MM



200x1200 MM



300x900 MM



200x900 MM



STRIPS



**20MM OUTDOOR
PORCELAIN TILES**



CEMENTINO GREY-600X1200 MM

20
MM
THICKNESS



R11

CEMENTINO NERO

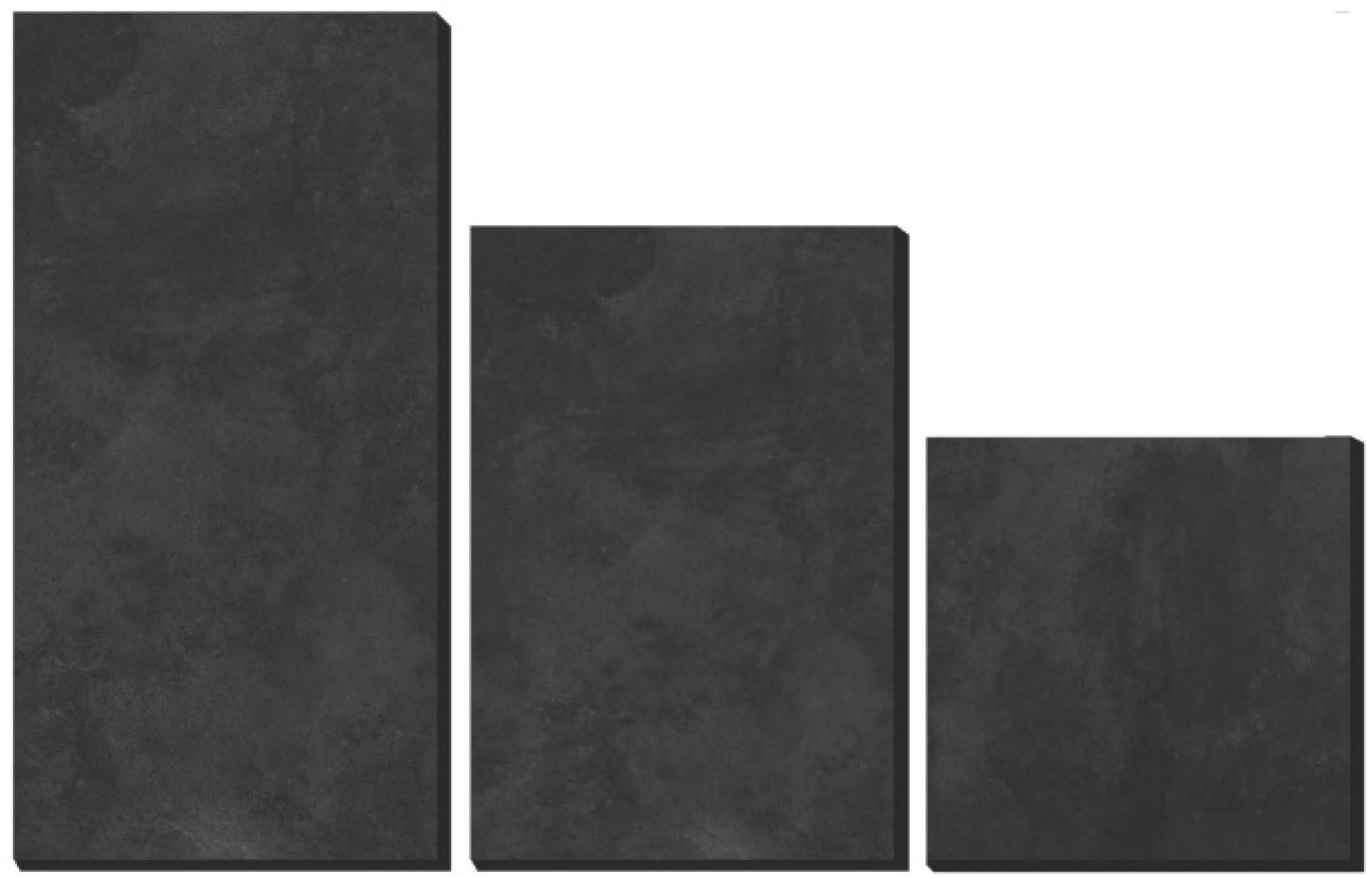

600x1200 MM 600x900 MM 600x600 MM

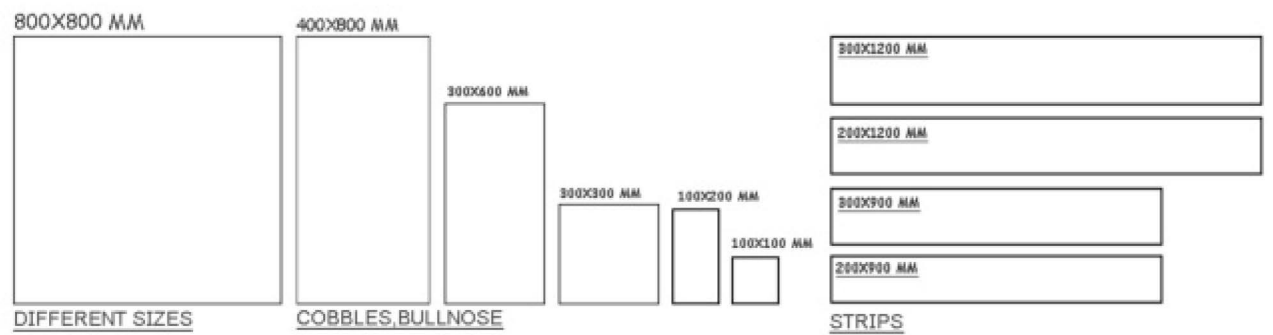

20
MM
THICKNESS

**20MM OUTDOOR
PORCELAIN TILES**



CEMENTINO NERO-600X900 MM

20
MM
THICKNESS



R11

COLORADO BEIGE



600x1200 MM 600x900 MM 600x600 MM

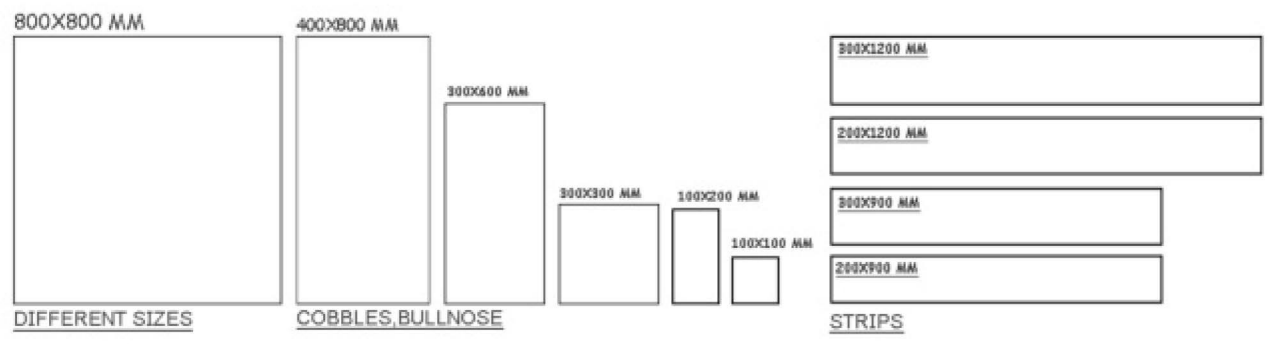

**20MM OUTDOOR
PORCELAIN TILES**



COLORADO BEIGE-600X600 MM

20
MM
THICKNESS

 **R11**

COUNTY ANTHRACITE

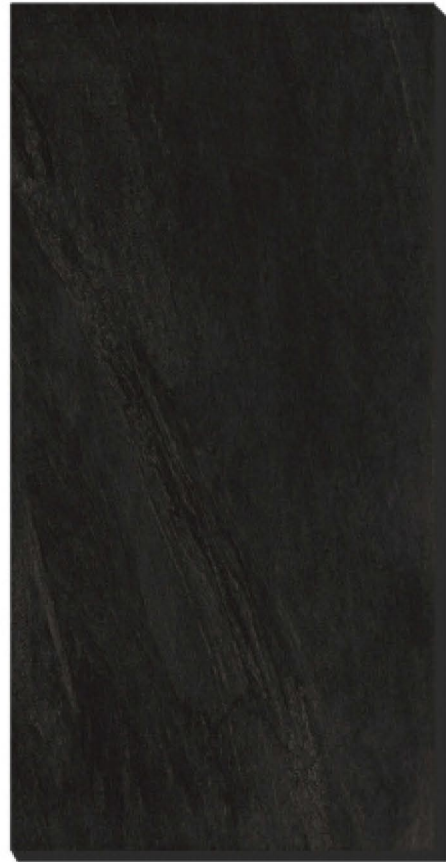

600x1200 MM



600x900 MM



600x600 MM

800x800 MM

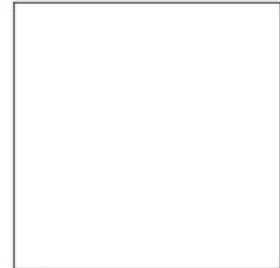

DIFFERENT SIZES

400x800 MM



COBBLES, BULLNOSE

300x600 MM



300x300 MM



100x200 MM



100x100 MM



800x1200 MM



200x1200 MM



800x900 MM



200x900 MM



STRIPS



**20MM OUTDOOR
PORCELAIN TILES**

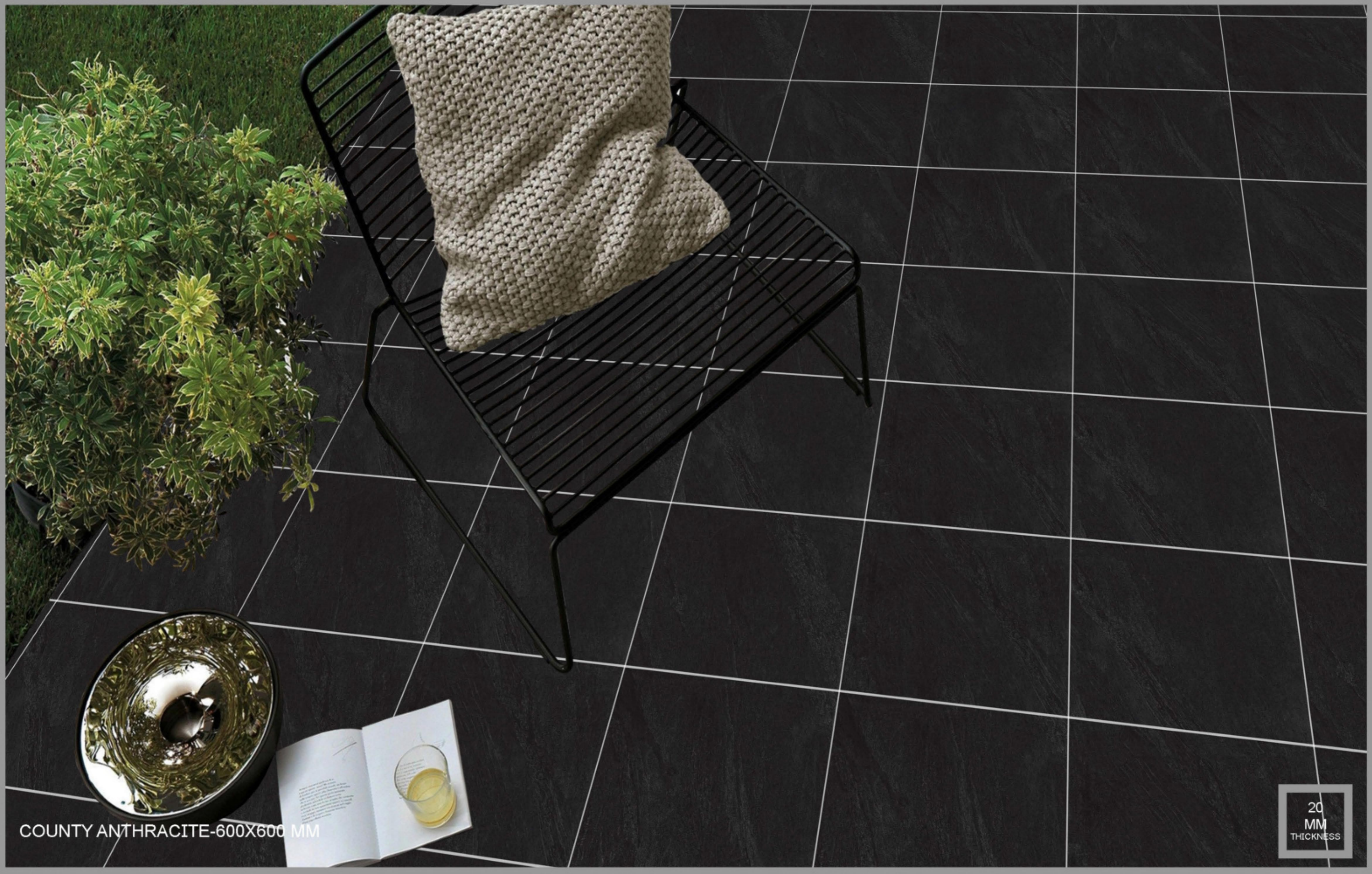

COUNTY ANTHRACITE-600X600 MM

20
MM
THICKNESS

R11

COUNTY CREMA



600x1200 MM 600x900 MM 600x600 MM

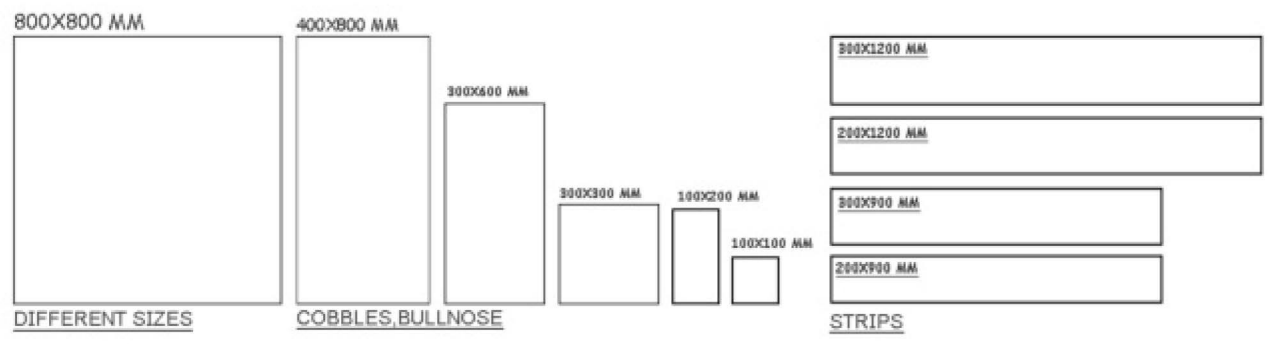

20 MM THICKNESS

20MM OUTDOOR PORCELAIN TILES



COUNTY CREMA-600X900 MM

20
MM
THICKNESS



R11

COUNTY GRIS



600x1200 MM



600x900 MM



600x600 MM

800x800 MM

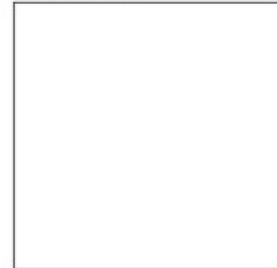

DIFFERENT SIZES

400x800 MM



COBBLES, BULLNOSE

300x600 MM



300x300 MM



100x200 MM

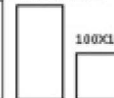

100x100 MM



800x1200 MM



200x1200 MM



300x900 MM



200x900 MM



STRIPS



**20MM OUTDOOR
PORCELAIN TILES**



COUNTY GRIS-600X900 MM

20
MM
THICKNESS



R11

COUNTY LGY

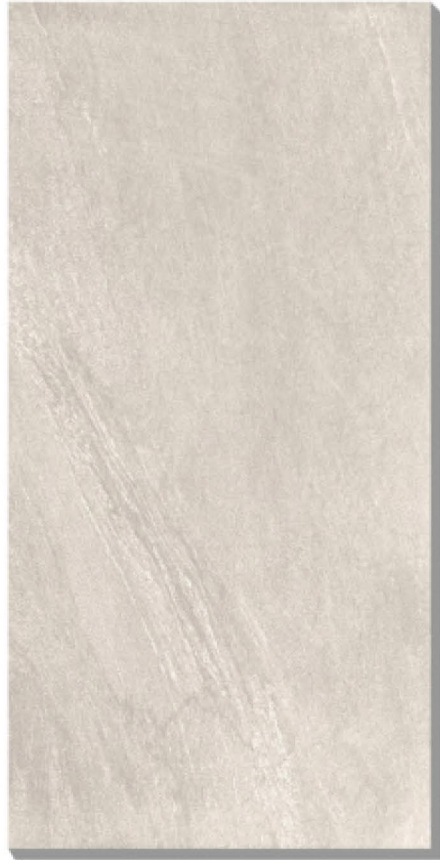

600x1200 MM



600x900 MM



600x600 MM

800x800 MM

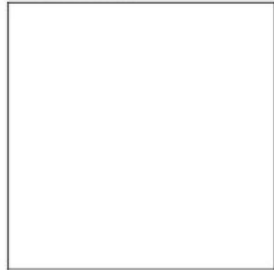

DIFFERENT SIZES

400x800 MM



COBBLES, BULLNOSE

300x600 MM

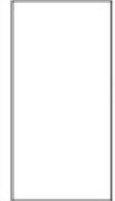

300x300 MM



100x200 MM

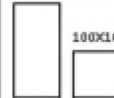

100x100 MM



800x1200 MM



200x1200 MM



800x900 MM



200x900 MM



STRIPS



**20MM OUTDOOR
PORCELAIN TILES**

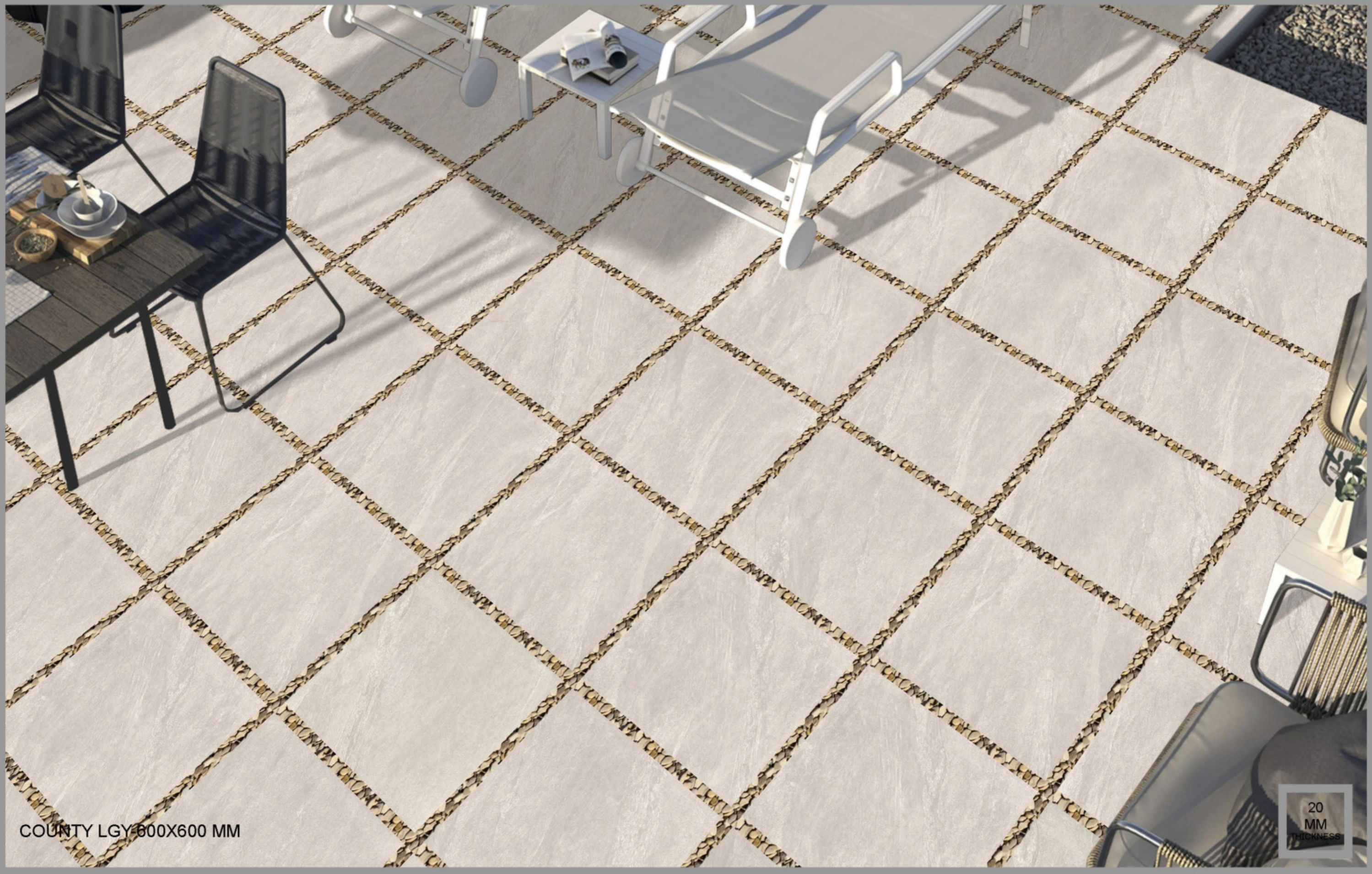

COUNTY LGY 600X600 MM

20
MM
THICKNESS



R11

CREEK WAVE NERO



600x1200 MM



600x900 MM



600x600 MM

800x800 MM

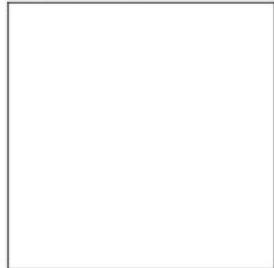

DIFFERENT SIZES

400x800 MM



COBBLES, BULLNOSE

300x600 MM



300x300 MM



100x200 MM

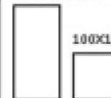

100x100 MM



800x1200 MM



200x1200 MM



300x900 MM



200x900 MM



STRIPS



**20MM OUTDOOR
PORCELAIN TILES**



CREEK WAVE NERO-600X600 MM

20
MM
THICKNESS

 **R11**

CROSSOVER GREY



600x1200 MM



600x900 MM



600x600 MM

800x800 MM

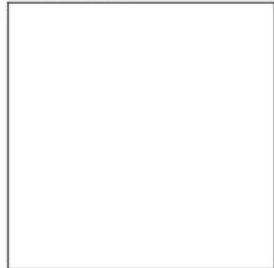

DIFFERENT SIZES

400x800 MM



COBBLES, BULLNOSE

300x600 MM



300x300 MM



100x200 MM



100x100 MM



800x1200 MM



200x1200 MM



300x900 MM

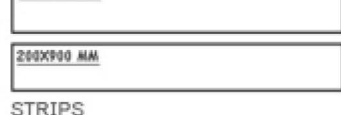

200x900 MM



STRIPS



**20MM OUTDOOR
PORCELAIN TILES**



CROSSOVER GREY-600X1200 MM

20
MM
THICKNESS



R11

CROSSOVER WHITE

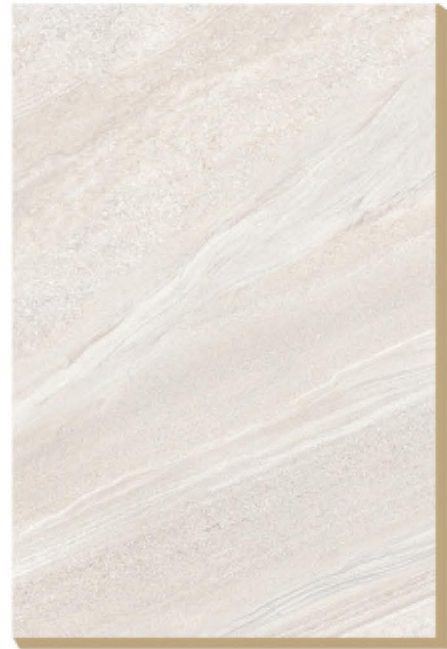

600x1200 MM

600x900 MM

600x600 MM

800x800 MM

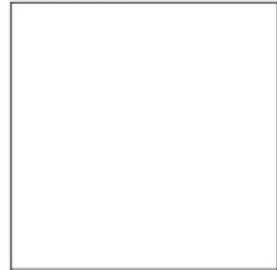

DIFFERENT SIZES

400x800 MM



COBBLES, BULLNOSE

300x600 MM



300x300 MM



100x200 MM

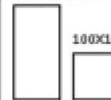

100x100 MM



800x1200 MM



200x1200 MM



300x900 MM



200x900 MM



STRIPS



**20MM OUTDOOR
PORCELAIN TILES**



CROSSOVER WHITE-600X1200 MM

20
MM
THICKNESS



R11

DOLCE NERO



600x1200 MM



600x900 MM

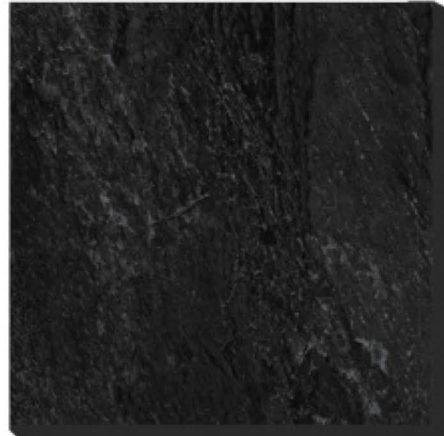

600x600 MM

800x800 MM

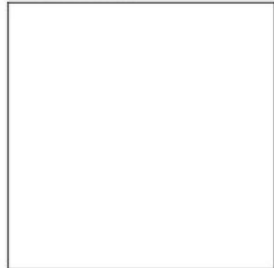

DIFFERENT SIZES

400x800 MM



COBBLES, BULLNOSE

300x600 MM

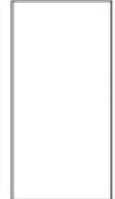

300x300 MM



100x200 MM



100x100 MM



800x1200 MM



200x1200 MM



800x900 MM



200x900 MM



STRIPS



**20MM OUTDOOR
PORCELAIN TILES**



DOLCE NERO-600X900 MM

20
MM
THICKNESS

EARTH WHITE



600x1200 MM

600x900 MM

600x600 MM

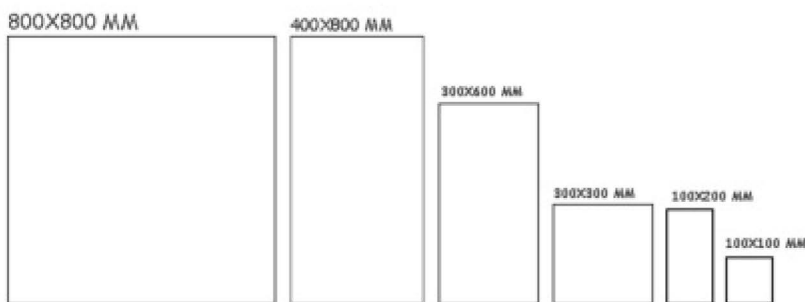

DIFFERENT SIZES

COBBLES, BULLNOSE

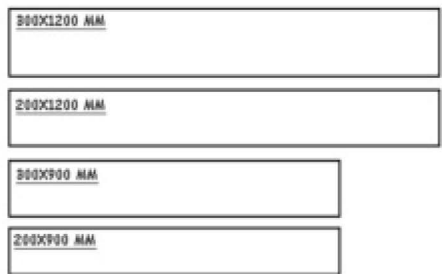

STRIPS



**20MM OUTDOOR
PORCELAIN TILES**



EARTH WHITE-600X600 MM

20
MM
THICKNESS



R11

EARTHCORE GREY



600x1200 MM



600x900 MM



600x600 MM

800x800 MM

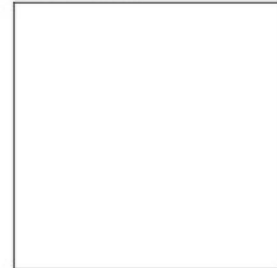

DIFFERENT SIZES

400x800 MM



COBBLES, BULLNOSE

300x600 MM



300x300 MM



100x200 MM

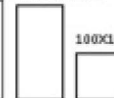

100x100 MM



800x1200 MM



200x1200 MM



300x900 MM



200x900 MM



STRIPS



**20MM OUTDOOR
PORCELAIN TILES**



EARTHCORE GREY-600X1200 MM

20
MM
THICKNESS



R11

GETAFE BEIGE



600x1200 MM

600x900 MM

600x600 MM

800x800 MM

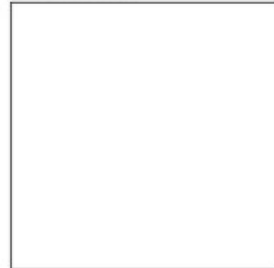

DIFFERENT SIZES

400x800 MM



COBBLES, BULLNOSE

300x600 MM



300x300 MM



100x200 MM

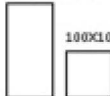

100x100 MM



800x1200 MM



200x1200 MM



800x900 MM



200x900 MM



STRIPS



**20MM OUTDOOR
PORCELAIN TILES**



GETAFE BEIGE-600X600 MM

20
MM
THICKNESS

R11

GETAFE GREY



600x1200 MM 600x900 MM 600x600 MM

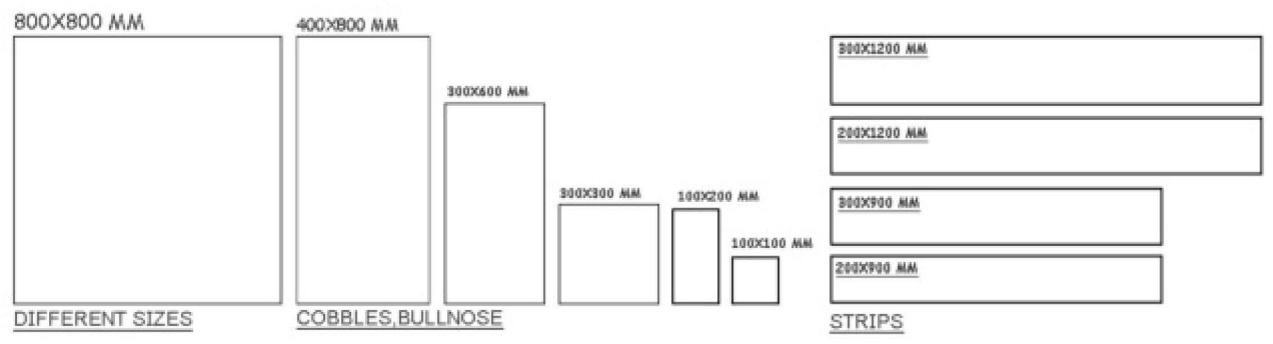

20 MM THICKNESS

20MM OUTDOOR PORCELAIN TILES



GETAFE GREY-600X600 MM

20
MM
THICKNESS

R11

HAMMERSTONE BEIGE



600x1200 MM 600x900 MM 600x600 MM

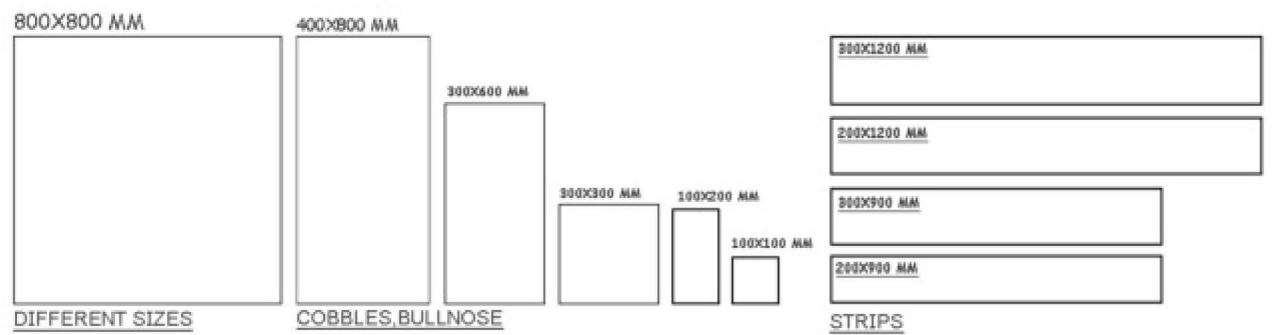

20
MM
THICKNESS

**20MM OUTDOOR
PORCELAIN TILES**



HAMMERSTONE BEIGE-600X600 MM

20
MM
THICKNESS



R11

HAMMERSTONE GREY



600x1200 MM



600x900 MM



600x600 MM



DIFFERENT SIZES

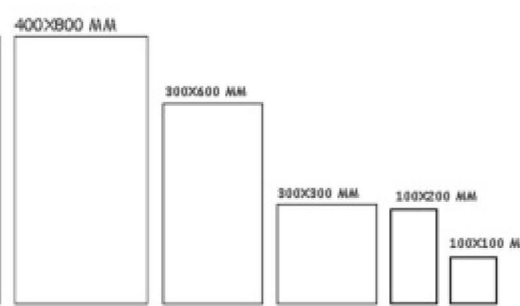

COBBLES, BULLNOSE

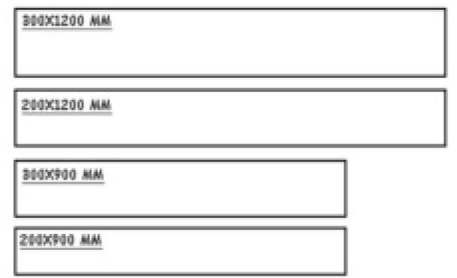

STRIPS



**20MM OUTDOOR
PORCELAIN TILES**



R11

HAMMERSTONE NERO



600x1200 MM



600x900 MM



600x600 MM



DIFFERENT SIZES

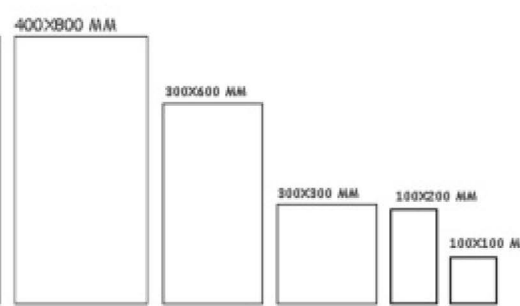

COBBLES, BULLNOSE

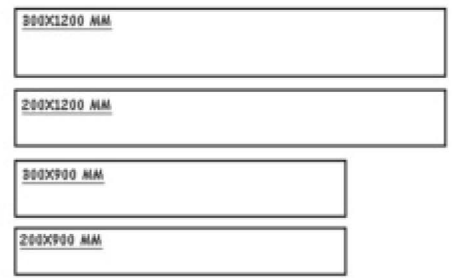

STRIPS



**20MM OUTDOOR
PORCELAIN TILES**



HAMMERSTONE NERO 600X1200 MM

20
MM
THICKNESS



R11

HIMALAYA BLACK

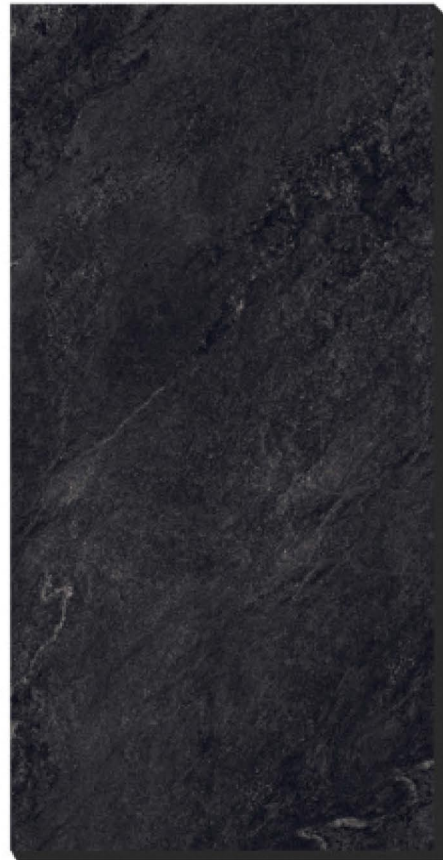

600x1200 MM

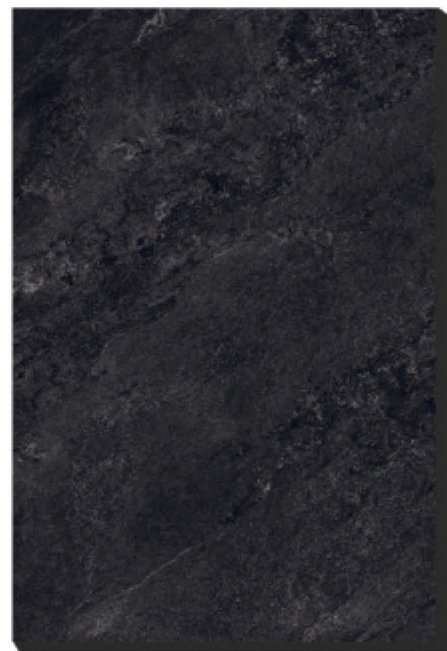

600x900 MM



600x600 MM

800x800 MM

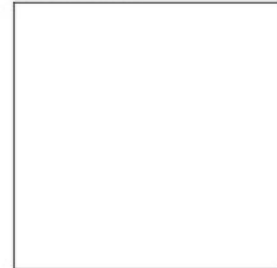

DIFFERENT SIZES

400x800 MM



COBBLES, BULLNOSE

300x600 MM



300x300 MM



100x200 MM

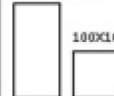

100x100 MM



800x1200 MM



200x1200 MM



800x900 MM



200x900 MM



STRIPS



**20MM OUTDOOR
PORCELAIN TILES**



HIMALAYA BLACK-600X900 MM

20
MM
THICKNESS



R11

HIMALAYA GREY



600x1200 MM



600x900 MM



600x600 MM

800x800 MM

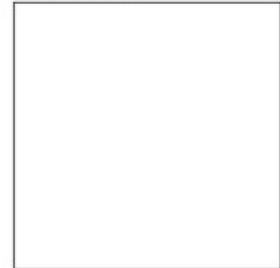

DIFFERENT SIZES

400x800 MM



COBBLES, BULLNOSE

300x600 MM



300x300 MM



100x200 MM

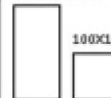

100x100 MM



800x1200 MM



200x1200 MM



300x900 MM



200x900 MM



STRIPS



20MM OUTDOOR
PORCELAIN TILES



HIMALAYA GREY 600X600 MM

20
MM
THICKNESS



R11

HIMALAYA WHITE



600x1200 MM

600x900 MM

600x600 MM

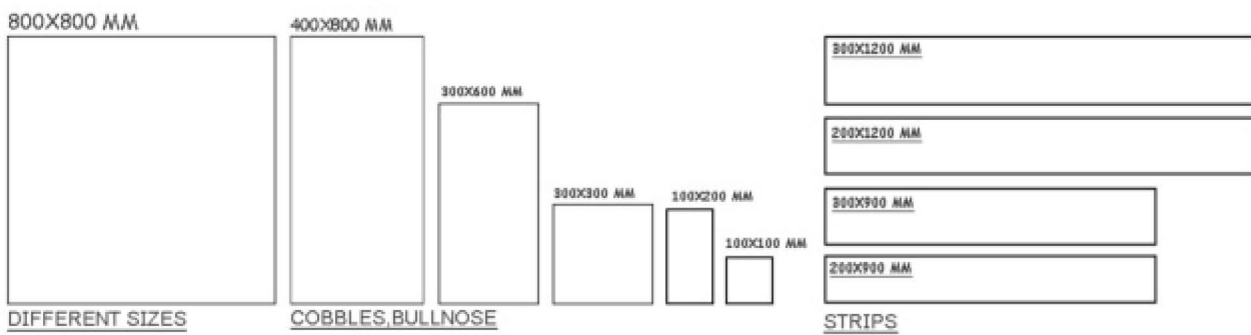

**20MM OUTDOOR
PORCELAIN TILES**



HIMALAYA WHITE 600X900 MM

20
MM
THICKNESS



R11

KANDLA GREY



600x1200 MM

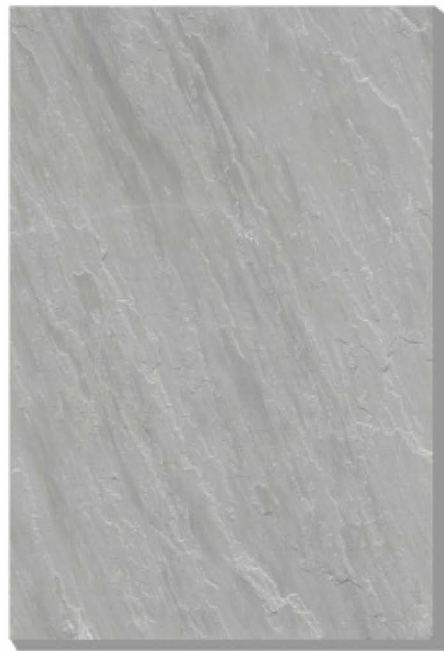

600x900 MM



600x600 MM

800x800 MM

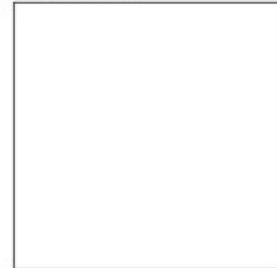

DIFFERENT SIZES

400x800 MM



COBBLES, BULLNOSE

300x600 MM



300x300 MM



100x200 MM

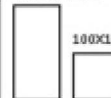

100x100 MM



800x1200 MM



200x1200 MM



800x900 MM



200x900 MM



STRIPS



**20MM OUTDOOR
PORCELAIN TILES**



KANDLA GREY-600X900 MM

20
MM
THICKNESS



R11

LAVA SLATE



600x1200 MM

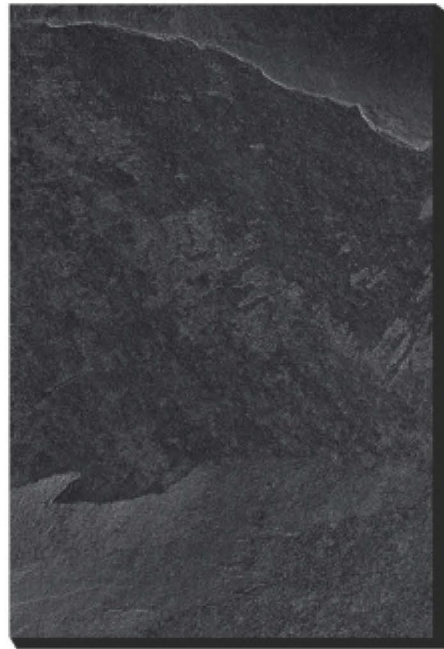

600x900 MM



600x600 MM

800x800 MM

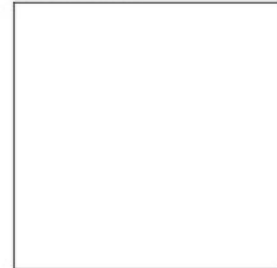

DIFFERENT SIZES

400x800 MM



COBBLES, BULLNOSE

300x600 MM



300x300 MM



100x200 MM

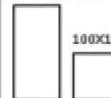

100x100 MM



800x1200 MM



200x1200 MM



300x900 MM



200x900 MM



STRIPS



**20MM OUTDOOR
PORCELAIN TILES**



LAVA SLAT-600X1200 MM

20
MM
THICKNESS



R11

LAVA STONE BEIGE



600x1200 MM

600x900 MM

600x600 MM

800x800 MM

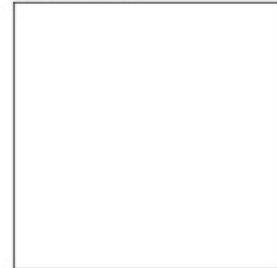

DIFFERENT SIZES

400x800 MM



COBBLES, BULLNOSE

300x600 MM



300x300 MM



100x200 MM

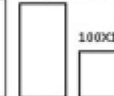

100x100 MM



800x1200 MM



200x1200 MM



300x900 MM



200x900 MM



STRIPS

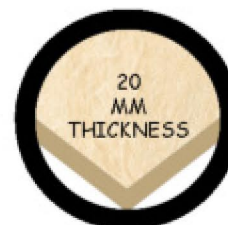

**20MM OUTDOOR
PORCELAIN TILES**



LAVA STONE BEIGE-600X900 MM

20
MM
THICKNESS

R11

LIMESTONE GREY



600x1200 MM 600x900 MM 600x600 MM

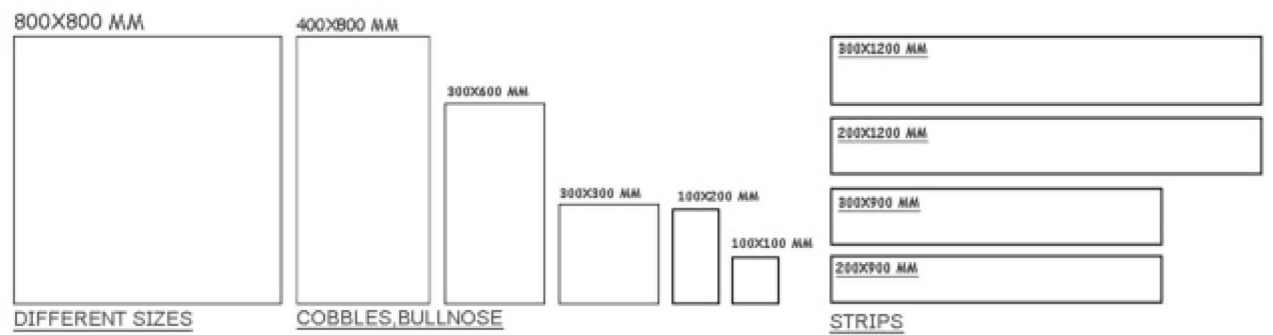

20 MM THICKNESS

20MM OUTDOOR PORCELAIN TILES



LIMESTONE GREY-600X900 MM

20
MM
THICKNESS

R11

LIMESTONE IVORY

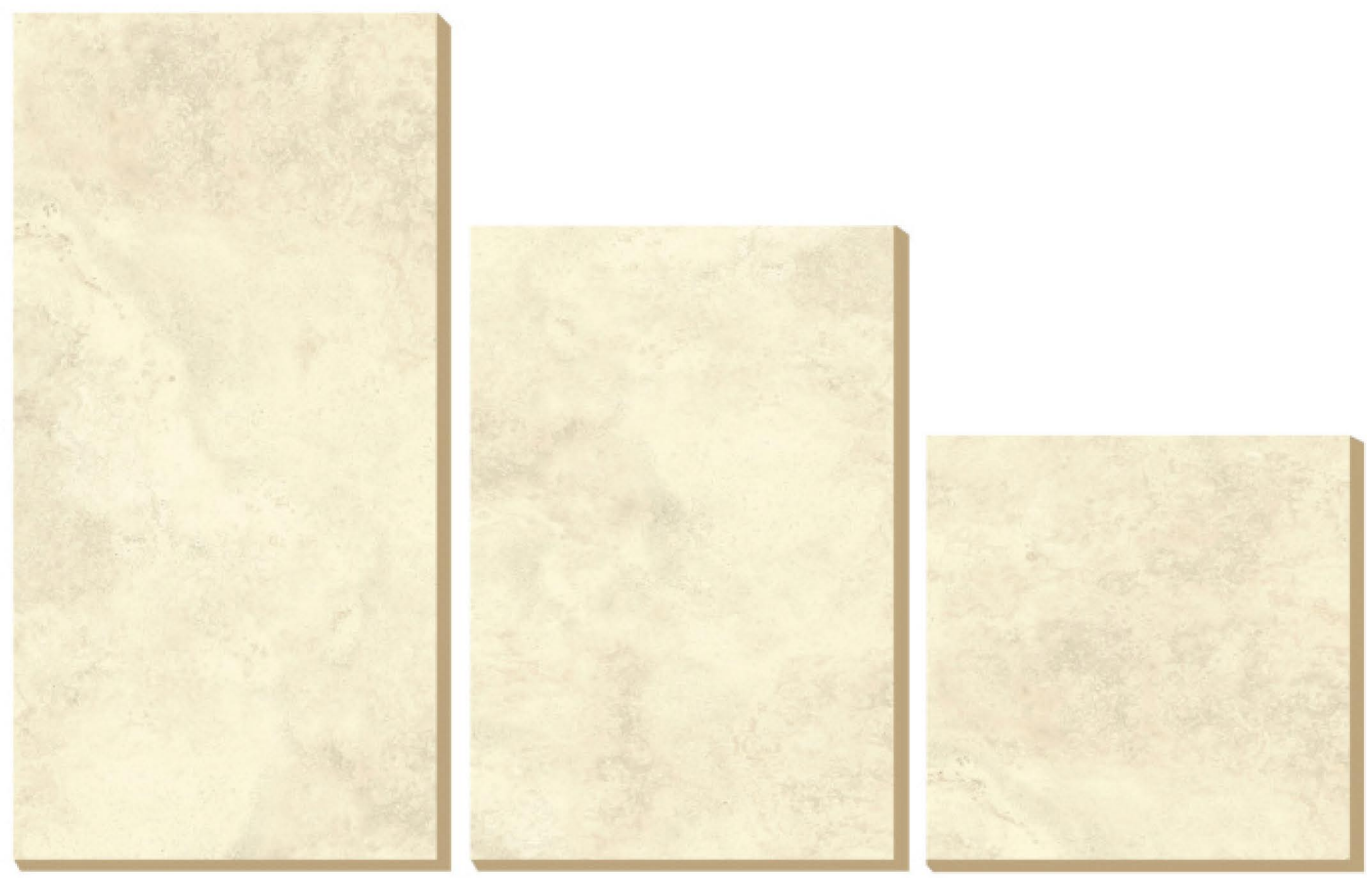

600x1200 MM 600x900 MM 600x600 MM

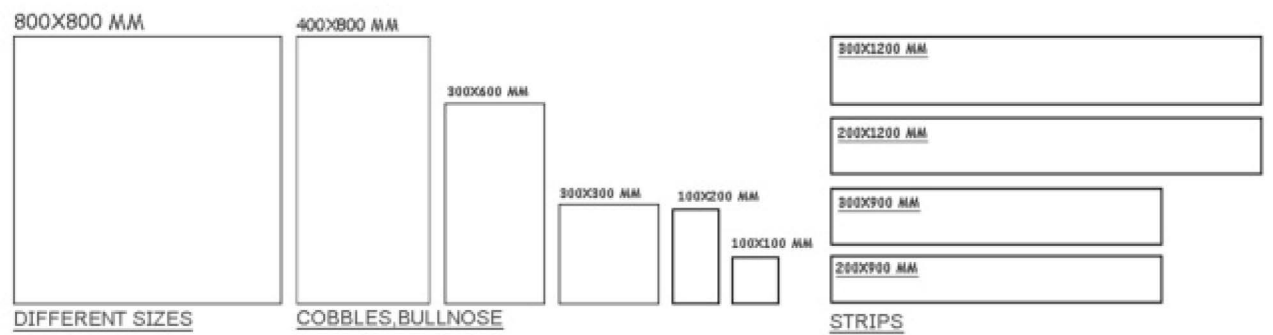

**20
MM
THICKNESS**

**20MM OUTDOOR
PORCELAIN TILES**



LIMESTONE IVORY-600X600 MM

20
MM
THICKNESS

PORCELAIN STONEWARE TILE 20MM FOR OUTDOOR FLOORING

20mm outdoor porcelain stoneware is the product with the highest technical performance, ideal for flooring in an outdoor environment without the risk of breakage and without interrupting the continuity between interior and exterior spaces. Resistant to frost and thermal

shock, it has intensified anti-slip characteristics and is easy to clean. The perfect union between high technical performance and aesthetics helps maintain the material and color unchanged over time, guaranteeing long-lasting durability.

VERSATILE



EASY TO LAY,
REMOVE AND REUSE



COLORS REMAIN
STABLE OVER TIME



CAN BE INSTALLED WITH DIFFERENT LAYING SYSTEMS



MULTIPLE AESTHETIC
VARIATIONS SEAMLESSLY
COMBINE OUTDOOR AND
INDOOR FLOORING



ATTENTION TO DETAIL
AND SPECIAL PIECES FOR
AESTHETIC RESULTS THAT
MAKE A GREAT IMPACT



RESISTANT



FROST-RESISTANT



FIRE-PROOF



RESISTANT TO STAINS,
ACIDS AND CHEMICAL AGENTS



RESISTANT TO SALT



RESISTANT
TO MOULD AND BACTERIA



HIGHLY RESISTANT
TO HEAVY LOADS



HIGH RESISTANCE
TO THERMAL SHOCK

FUNCTIONAL



NON-SLIP SURFACES



RESISTANT TO VEHICULAR
PASSAGE IF APPLIED TO A
SCREED



ECO-FRIENDLY



LEED COMPLIANT

ECO-FRIENDLY



EASY TO CLEAN

INTENDED USES

Owing to the possibility of installing it dry (on grass, sand, gravel, and elevated floors) the 20mm porcelain outdoor tile collection is the

most versatile solution for exterior floors in residential and public areas.

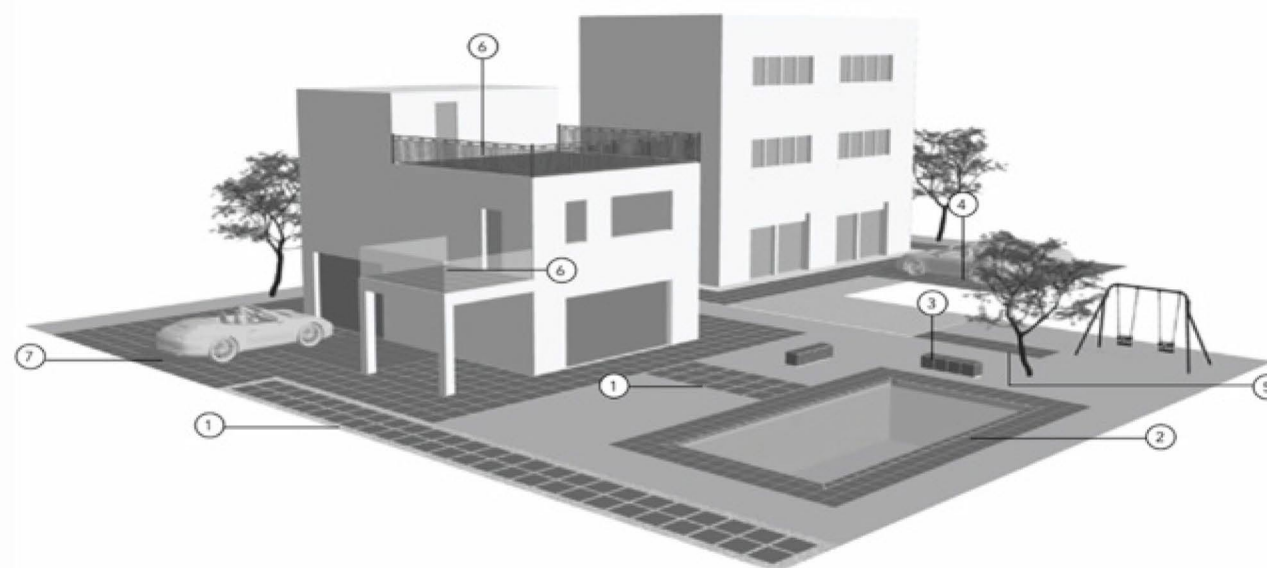

1 DRIVEWAYS AND
PATHWAYS

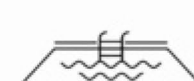

2 SWIMMING POOLS, SPAS
AND ADJOINING AREAS



3 URBAN FURNITURE
AND PUBLIC PLACES



4 HIGH-TRAFFIC
INDUSTRIAL ZONES



5 PUBLIC PARKS
AND GARDENS



6 TERRACES AND
BALCONIES



7 CAR PARKS
AND DRIVEWAY AREAS



OTHER APPLICATION
SOLUTIONS

LAYING SOLUTIONS

Outdoor porcelain 20mm tiles are an innovative solution that is very versatile due to the numerous laying possibilities they offer: dry

DRY INSTALLATION ON GRASS



a. Easy to lay, adjust, and move. An ideal solution for public parks and private gardens.



DRY INSTALLATION ON GRAVEL / SAND



b. Easy to lay, adjust, and move. Boasts ideal aesthetic features to enhance contemporary buildings.



INSTALLATION ON SCREED WITH ADHESIVE



c. Build resilient and durable outdoor spaces, pathways, driveways, and more with the installation of 20mm tiles on screed with adhesive.



ELEVATED FLOOR INSTALLATION



d. Easily removable, inspectable, and reusable. Ideal to be applied with different kinds of support and is apt for concealing wiring pipes, and more with accessibility.

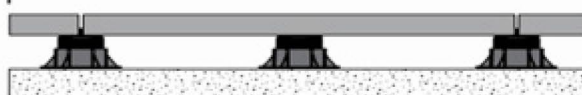

CAUTION

- When carrying out an elevated floor installation it is recommended to check the intended use and to follow the installation instructions.
- In the case of external dry installation, the force of the wind, in particular types of applications or geographical locations, can cause the lifting of the tiles. It is recommended that the designer/client always check the suitability of the installation system selected according to local regulations in force.
- Failure to follow the above recommendations may result in misuse of the product and cause injury to persons and/or damage to property.

installation on grass, gravel, or sand, screed with adhesive, and elevated floor installation.

DRY INSTALLATION ON GRASS

To create a pathway with stepping stones, first of all, it is important to determine the number of steps necessary for the entire path, making sure that the tiles are positioned equidistantly. So as to obtain maximum stability, it is recommended to

dig out about 5/8cm from the soil, and then place a fine layer of gravel. Compact the substrate and then position the tile. To allow the turf to grow well, it is advisable to leave a gap of at least 10cm between one tile and another.



SAFE AND STABLE



LONG-LASTING



EASY TO CLEAN



DRAINS

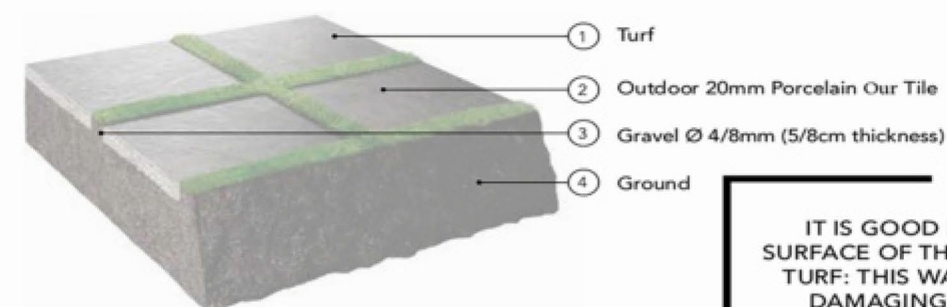

IT IS GOOD PRACTICE TO LAY THE SURFACE OF THE TILES IN LINE WITH THE TURF: THIS WAY THERE IS NO RISK OF DAMAGING THE LAWN MOWERS.

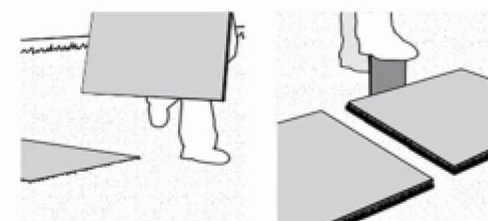

1/2

To determine the correct sizing and positioning of the flooring, place the tiles on the ground and carefully position them equidistant from each other. Mark the perimeter of the tile using a spade in the soil.

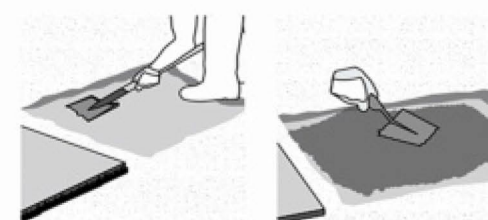

3/4

Remove the turf and dig out about 5cm of soil. Form a stable and uniform substrate using fine gravel (grain size 4/8mm).

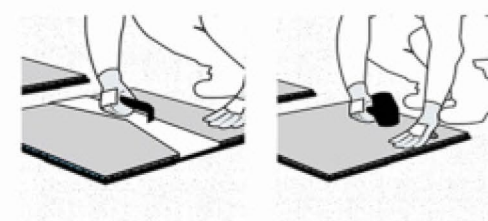

5/6

Lay the tile, so as to have an approximately 0.5cm level difference, between the tile and the ground. To simplify tile installation it is possible to use suitable tile installation handles. Knock the tile along the edges with a rubber hammer until it is at the same level as the turf.

CAUTION

The application layers proposed are to be taken as an indication, and have the sole purpose of showing how to obtain a correct flooring.

DRY INSTALLATION ON GRAVEL / SAND

For installation on sand it is good to remember to place a geotextile on the gravel, on which to spread out a layer (from 2 to 5cm thick) of dry sand with a grain size of 0/2mm. It is necessary to compact the sand with a vibro-compacting plate

before proceeding with the installation of the tiles. For particular uses and for stressful loads, it is advisable to consult a technician in order to calculate precisely the thicknesses of the various layers of the substrate.



SAFE AND STABLE



LONG-LASTING



EASY TO CLEAN



DRAINS

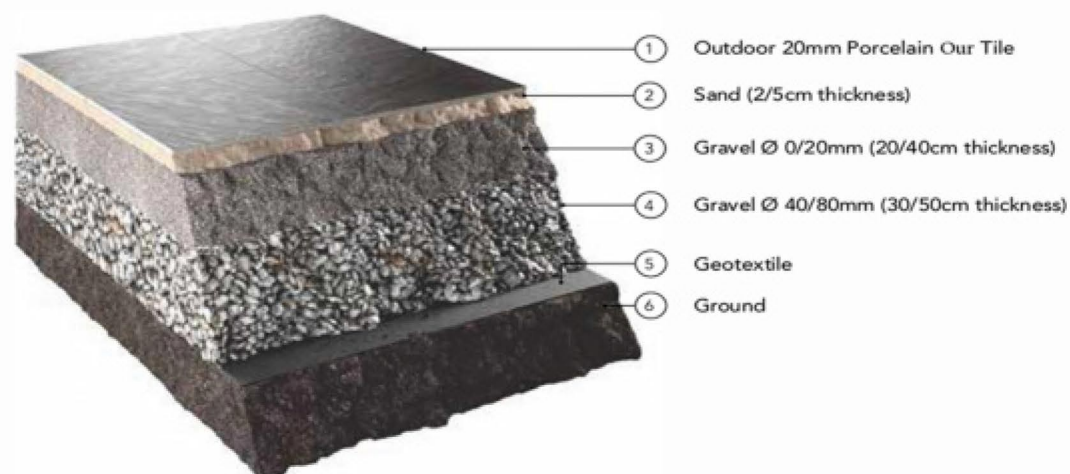

CAUTION

The application layers proposed are to be taken as an indication, and have the sole purpose of showing how to obtain a correct flooring. It is recommended to always refer to the specific norms and regulations in each individual country and the instructions of the project supervisor.

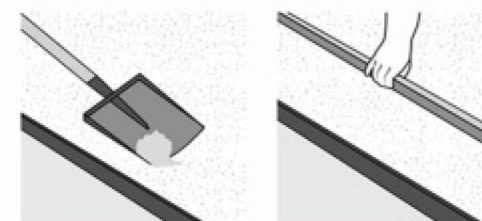

1/2

Form a stable and uniform substrate using fine gravel or sand. Level the substrate with a metal straight edge.

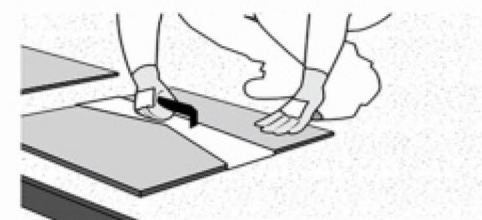

3

Position the tile and then compact the edges in order to level the tile with the substrate. It is suggested to use a joint of at least 4mm to allow good water drainage.



IN ORDER TO AVOID THE DISPLACEMENT OF THE SUBSTRATE AND CONSEQUENTLY THE TILES, THE SUBSTRATE MUST BE PARTITIONED WITH CONTAINMENT EDGES OR PERIMETER CURBS.

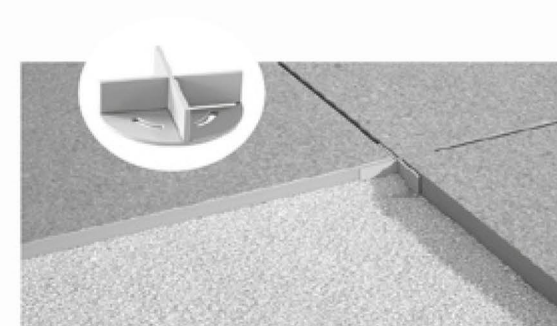

Spacers designed for laying tiles on sand or gravel are an extremely versatile and practical system despite their simplicity. The support is made up of a head with a spacer cross and a removable tip: the fins of the head cross help position the tiles and create the joint between them, ensuring that over time the flooring maintains its correct positioning. The tip is specific for application on sand: the elongated shape guarantees the anchorage and stability of the tiles, preventing them from slipping. For use on gravel, it is possible to remove the tip and place the spacer head directly on the gravel.

INSTALLATION ON SCREED WITH ADHESIVE

For installation on screed with adhesive we recommend a joint of at least 5mm. The size and position of the expansion joints must be established by the project supervisor; they must have an indicative width ranging from 4 to 12mm and divide the surface to be paved in a uniform

pattern with dimensions ranging from approximately 3x3m to 4x2.5m. To facilitate the flow of rainwater, it is always necessary to assess the slopes of outdoor paving; when laying with adhesives on screed, the slopes are determined by the latter.



SAFE AND STABLE



LONG-LASTING



EASY TO CLEAN



RESISTANT TO VEHICULAR
PASSAGE

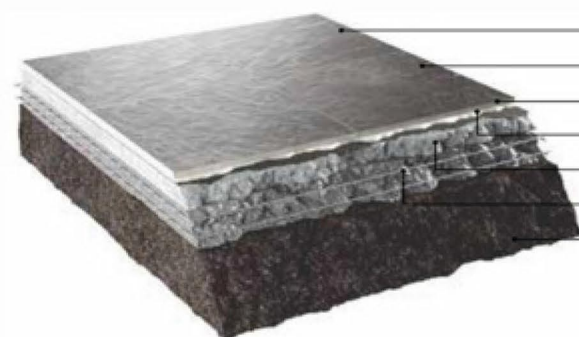

- ① Grout min CG2W (EN 13888)
- ② Outdoor 20mm Porcelain Our Tile
- ③ Adhesive for exteriors min C2ES1 (EN 12004)
- ④ Possible waterproofing layer (2/4mm thick)
- ⑤ Sloping screed (5/10cm thick - slope >1.5%)
- ⑥ Concrete reinforced with electro-welded mesh (10/25cm thick)
- ⑦ Ground

IN ORDER TO AVOID AESTHETICALLY UNPLEASANT CUTS OF THE TILES, IT IS SUGGESTED TO DEFINE THE SLOPES OF THE SCREED TAKING INTO ACCOUNT THE SIZE CHOSEN FOR THE INSTALLATION.

CAUTION

The application layers proposed are to be taken as an indication, and have the sole purpose of showing how to obtain a correct flooring. It is recommended to always refer to the specific norms and regulations in each individual country and the instructions of the Project Supervisor.

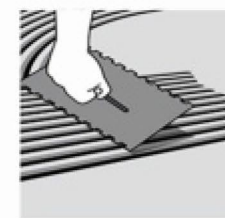
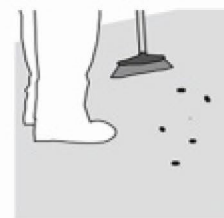

1/2

Before proceeding with the installation clean the substrate thoroughly. In order to obtain a flat floor, it is important to apply an even layer of adhesive.

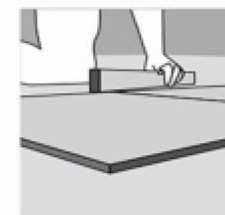
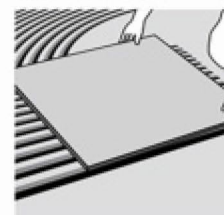

3/4

Check the planarity of the flooring regularly during the laying operations.



5/6

Once the installation is finished grout the flooring. Remember to observe the times indicated by the manufacturer for light foot traffic before walking on the tiles. "Post-installation" cleaning is mandatory at the end of the work and is required to remove residues of cement, lime or grout used for laying and filling the joints.

Expansion joints

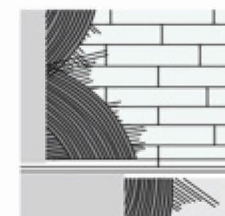
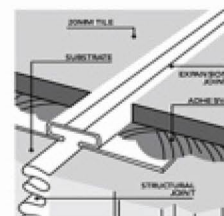

1/2

In correspondence with a structural or dividing joint in the screed, it is mandatory to provide an expansion joint with a width that is at least the size of the existing one. If there are joints between different surface types, it is mandatory to provide an expansion joint.

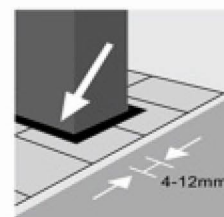

3

Around fixed elements of the supporting structure, such as walls, steps, columns, etc., it is mandatory to provide peripheral joints with a width of between 4 and 12mm.

ELEVATED FLOOR INSTALLATION

The elevated floor technology offers many specific and immediately perceivable advantages: it allows the passage of cables, pipes and necessary installations to be managed easily; it enables the underfloor to be inspected easily and guarantees an effective draining of rainwater. Thanks to the presence of

independent elements, elevated floors absorb expansion and structural movements, thus avoiding the formation of cracks on the waterproof embrane. The absence of the screed makes it possible to substantially reduce the weight that burdens the structures, while offering a high resistance to loads.

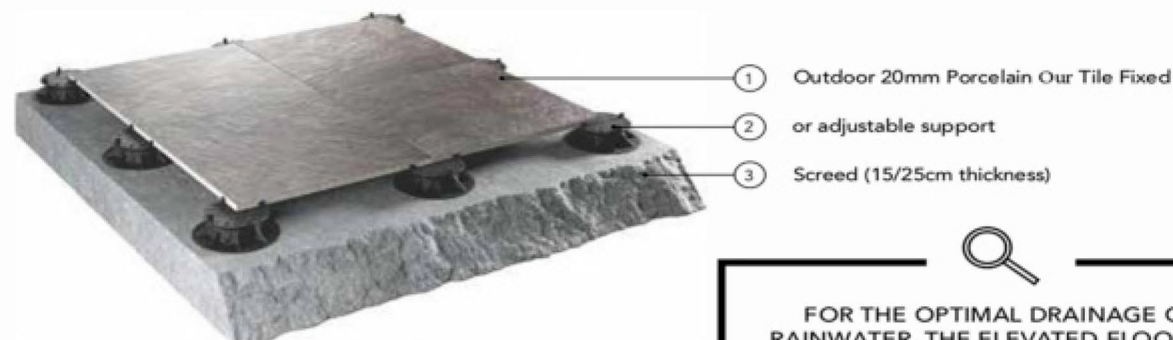

FOR THE OPTIMAL DRAINAGE OF RAINWATER, THE ELEVATED FLOORING MUST BE INSTALLED WITH A SLOPE OF BETWEEN 1.5% AND 2%.



1 The installation on the plastic supports must only be done on perfectly waterproof substrates. Before proceeding with the installation clean the substrate thoroughly.

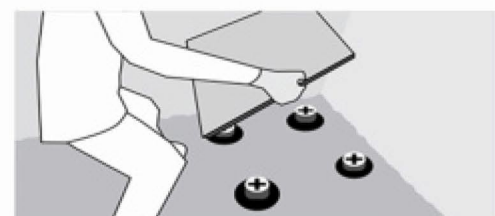

2 With regard to the number and position of the supports, as well as the type of reinforcement on the back of the slab, it is recommended to follow the instructions given in the following table, which are essential to evenly distribute the load.

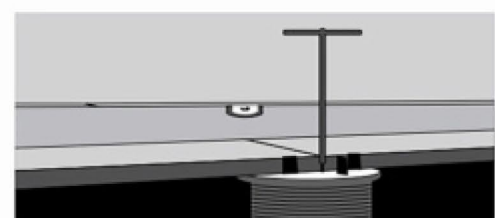

3 With the use of the special adjustment key it is possible to obtain a perfectly stable surface and with the required slope for better water drainage.

CAUTION

The application layers proposed are to be taken as an indication, and have the sole purpose of showing how to obtain a correct flooring. It is recommended to always refer to the specific norms and regulations in each individual country and the instructions of the project supervisor.

ELEVATED FLOOR INSTALLATION - SUPPORTS

Fixed supports and self-levelling adjustable supports

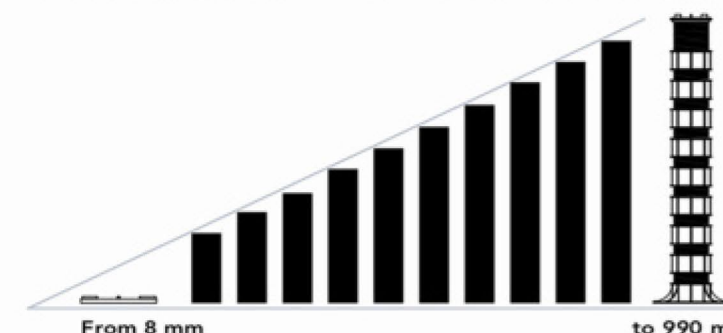

The structure of the supports consists of a base (which rests on the slab), a central screw adjustable in height and a head (on which the tile rests) which can be fixed or self-levelling with a self-adjustment system to alter inclination by up to 5°.

Technical characteristics of the supports

	They are made entirely of recycled and recyclable material
	Resistant to both acidic and alkaline solutions
	Resistant to atmospheric agents
	Resistant to temperatures of between -30 °C and +120°C
	Resistant to the crushing test with a load superior to 1 tonne
	Made of polypropylene
	Noise reduction of up to 25dB
	Possibility of using supports made with self-extinguishing material, which prevents the propagation of flames

Format	Elevated floor installation up to 2cm	Elevated floor installation 2-10cm	Elevated floor installation 10-30cm	Elevated floor installation 30-99cm
40x60cm	4 SUPPORTS 3+4 sup/m ²	4 SUPPORTS 3+4 sup/m ²	4 SUPPORTS + Reinforcement system or substructure of aluminium beams 3+4 sup/m ²	4 SUPPORTS + Reinforcement system or substructure of aluminium beams 3+4 sup/m ²
40x90cm	6 SUPPORTS 3+4 sup/m ²	6 SUPPORTS + Reinforcement system or substructure of aluminium beams 3+4 sup/m ²	6 SUPPORTS + Reinforcement system or substructure of aluminium beams 3+4 sup/m ²	6 SUPPORTS + Reinforcement system or substructure of aluminium beams 3+4 sup/m ²
40x120cm	6 SUPPORTS 3+4 sup/m ²	6 SUPPORTS + Reinforcement system or substructure of aluminium beams 3+4 sup/m ²	6 SUPPORTS + Reinforcement system or substructure of aluminium beams 3+4 sup/m ²	6 SUPPORTS + Reinforcement system or substructure of aluminium beams 3+4 sup/m ²

SPECIAL ELEMENTS

In order to guarantee excellent aesthetics and functionality for the various possible applications, the 20mm outdoor porcelain

Our tile collections have a rich set of step elements and special pieces.

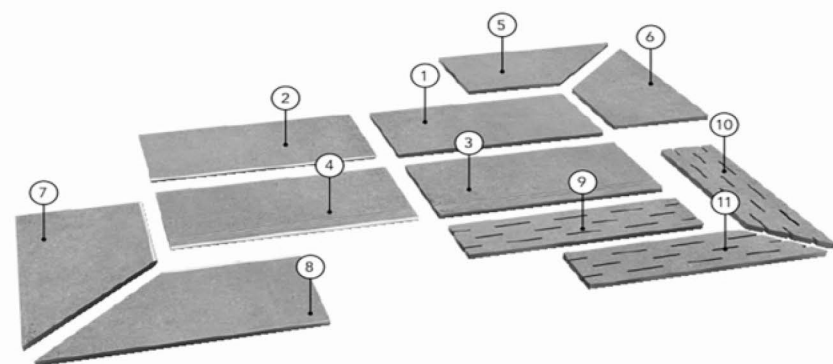

- ① Stair tile with straight edge
- ② Stair tile with rounded edge
- ③ Stair tile with straight ribbed edge
- ④ Stair tile with rounded ribbed edge
- ⑤ Right corner piece with straight edge
- ⑥ Left corner piece with straight edge
- ⑦ Left corner piece with rounded edge
- ⑧ Right corner piece with rounded edge
- ⑨ Grid
- ⑩ Right corner grid
- ⑪ Left corner grid

For the full range of special elements refer to the product catalogue.

STAIR TILE WITH STRAIGHT EDGE

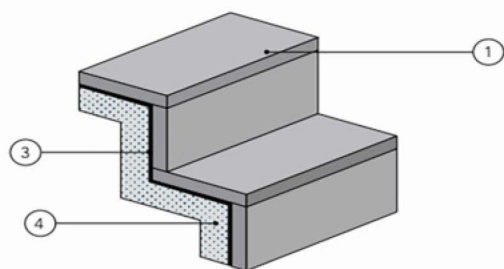

STAIR TILE WITH ROUNDED EDGE

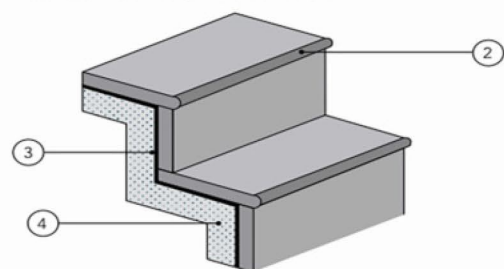

SWIMMING POOL EDGE

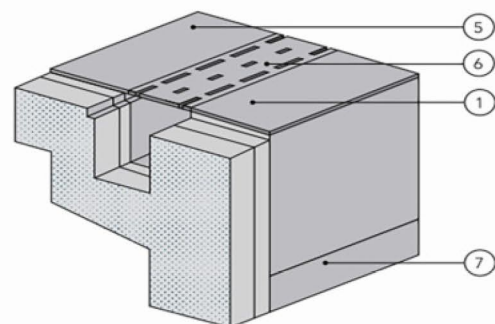

- ① Stair tile with straight edge
- ② Stair tile with rounded edge
- ③ Adhesive
- ④ Screed
- ⑤ Flooring
- ⑥ Grid
- ⑦ Swimming pool covering

CAUTION

The images are to be taken as an indication, and have the sole purpose of showing how to obtain a correct flooring. It is recommended to always refer to the specific norms and regulations in each individual country and the instructions of the project supervisor.

TECHNICAL SPECIFICATIONS

TEST DESCRIPTION	ISO-13006/EN176 GROUP BIA	MEAN VALUE OF OUR	TEST METHOD
Length & width	±0.6 %	±0.3mm	Passed
thickness 14mm	±5 %	±0.3mm	Passed
Straightness of side	±0.5 %	±0.3 %	Passed
Rectangularity	±0.6 %	±0.3 %	Passed
Surface flatness	±0.5 %	+0.35mm to -0.1 mm	Passed
Surface quality	Minimum 95 %	Minimum 95 %	Passed
Water absorption	< 0.5 %	< 0.04 %	Passed
Breaking strength	> 1300N	> 1500N	Passed
Flexural strength (Average)	> 35N/mm ²	> 40N/mm ²	Passed
Scratch hardness of surface (Moh's scale)	> 6	> 6	Passed
Resistance to deep abrasion	<175mm ³	<144mm ³	Passed
Skid Resistance (Friction coefficient)	>0.4	>0.4	Passed
Bulk Density, in (g/cc)	>2	>2	Passed
Linear Thermal expansion	Max. 9.0 ⁻⁴ x K ⁴ , Max	Max. 9.0 ⁻⁴ x K ⁴ , Max	Passed
Thermal shock resistance	No damage	No damage	Passed
Frost resistance	Frost proof	Frost proof	Passed
Resistance to Chemical	Resistance	Resistance	Passed
Resistance to Stain	Resistant	Resistant	Passed
Moisture expansion	Nil	Nil	Passed
Colour resistance	Resistant	Resistant	Passed
Glossiness (Polished)	-	-	Passed

PACKING DETAILS

SIZE	WEIGHT/BOX (KG)	PIC/BOX	WEIGHT/PLT (KG)	BOXES/PLT	PLT/CTN	BOXES/CTN	MT ² /BOX	MT ² /PLT	MT ² /CTN	WIGHT/CTN
600x1200mm (20mm)	32.5	1	30	30	28	840	0.72	21.6	604.8	28000
600x900mm (20mm)	24.5	1	30	40	28	1120	0.54	21.6	604.8	28280
600x600mm (20mm)	32.75	2	30	32	26	832	0.72	23.04	599.04	28028
400x800mm (20mm)	-	-	-	-	-	-	-	-	-	-

PACKING DETAILS (PATIOPACK)

SIZE	PCS/CRAT	M2/PCS	SQFT/PCS	M2/CRATE	SQFT/CRATE	IN KGS/CRATE	CRATE/CTN	CRATE/CTN	IN KGS/PLT	IN KGS/CTN
600x900mm (20mm)	13	0.54	5.81	7.02	75.56	530.40	532.71	36	730	26280
600x600mm (20mm)	13	0.36	3.88	4.68	50.38	235.76				
296x600mm (20mm)	13	0.18	1.94	2.31	25.18	58.14				
296x296mm (20mm)	9	0.09	0.79	0.79	7.10	5.60				
	48			14.80	158.21	829.89	532.71	36.00	730.00	26280.00